

THE

# RADIO CONSTRUCTOR

Vol. 25 No. 1

AUGUST 1971

20p

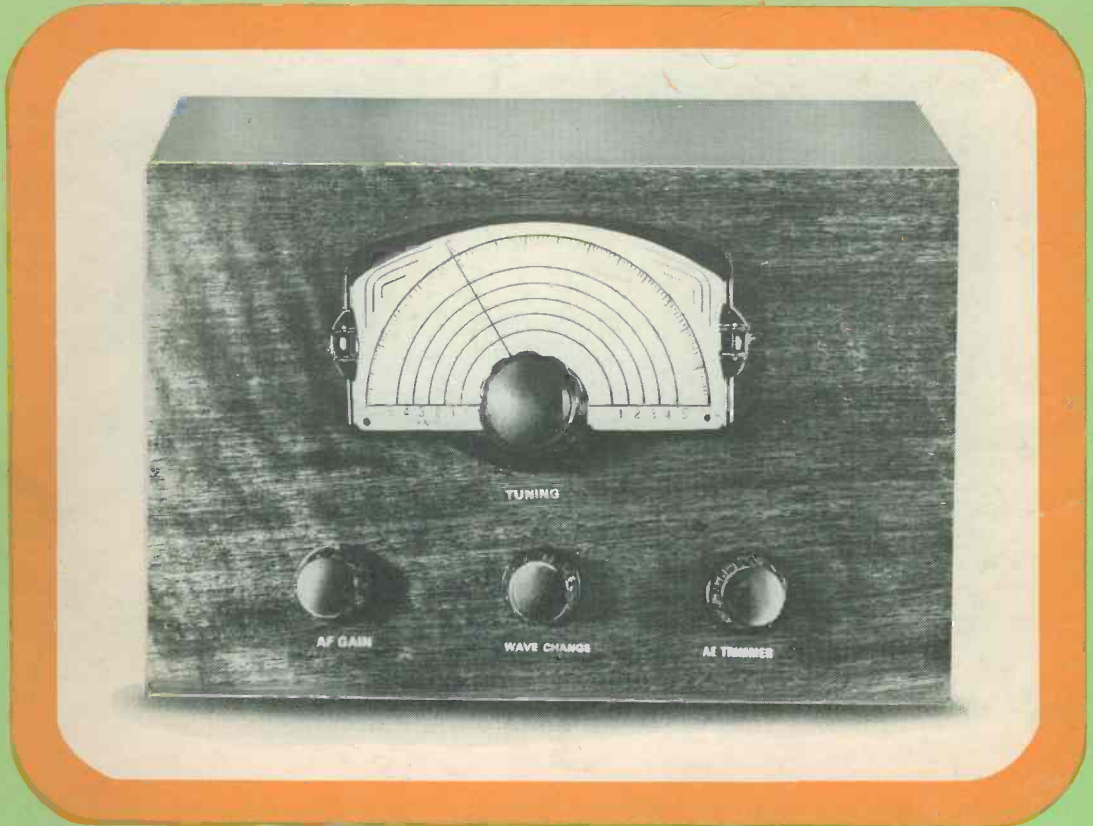

## THE BANDMASTER

Simple Superhet Receiver

**FEATURED**  
**IN THIS ISSUE**

**F.E.T. REFLEX RECEIVER**

**THE TRANSIMATCH**



**1** Household contents and personal possessions up to £600



**2** All Risks cover on personal belongings up to £60



**3** Personal accident insurance (road, rail and sea risks) - £3 per week



**4** Loss of cash up to £20



**5** Household removal cover up to £600



**6** All Risks cover on sports equipment up to £30



**7** Personal liability cover for the family up to £20,000



**8** Cover on Radio Television etc. for damage in the home up to £50

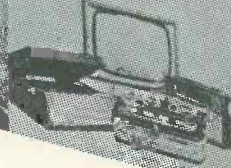

**9** Holiday deposits cover up to £20



**Each £3 unit of Home Unit Insurance gives you protection up to the limit shown**

This is the simplified insurance you have been waiting for. Not just cover on the contents of your home but a package of personal protection you and your family need. And it's how we save you so much money: just ONE policy to issue instead of nine! You can build up to the cover you need by additional units

(or 1/2 units after the first) up to a maximum of five. So simple. So easy. Apply to your Broker, Agent or local office of a General Accident company. The Home Unit Policy can replace your existing insurances. And remember - as you buy more possessions just add more Home Units at any time.

**THE YORKSHIRE INSURANCE COMPANY LIMITED**

Becket House, 36-37 Old Jewry, LONDON, E.C.2.

It pays to be protected by a **General Accident** company

Please send me further particulars of the Home Unit Insurance.

Name.....

Address.....

.....

.....



# THE MODERN BOOK CO

## COLOUR TELEVISION

### PICTURE FAULTS

There are over 120 illustrations, including 88 colour photographs

£2.50

Postage 5p

**Making & Repairing Transistor Radios**  
by W. Oliver £1 Postage 10p

**ABC's of FET's**  
by R. P. Turner £1.25 Postage 5p

**ABC's of Integrated Circuits**  
by R. P. Turner £1.25 Postage 5p

**Transistor Audio & Radlo Circuits**  
by Mullard £1.50 Postage 8p

**Transistor Pocket Book**  
by R. G. Hibberd £1.40 Postage 10p

**110 Semiconductor Projects For The Home Constructor**  
by R. M. Marston £1.20 Postage 5p

**HI-Fi In The Home**  
by J. Crabbe £2 Postage 10p

**1971 World Radio-TV Handbook**  
by J. M. Frost £2.30 Postage 8p

**VHF-UHF Manual** by G. R. Jessop  
£1.60 Postage 12p

**Foundations Of Wireless & Electronics**  
by M. G. Scroggie £1.80 Postage 15p

**Radlo Communication Handbook**  
by The R.S.G.B. £3.15 Postage 25p

**F.M. Radlo Servicing Handbook**  
by Gordon J. King £3 Postage 10p

**Radio Valve & Transistor Data**  
by A. M. Ball 75p Postage 10p

**The Radio Amateur's Handbook 1971**  
by A.R.R.L. £2.60 Postage 25p

We have the Finest Selection of English and American Radlo Books in the Country

**19-21 PRAED STREET (Dept RC) LONDON W2 IPN**

Telephone 01-723 4185

## DENCO (CLACTON) LIMITED

**355-7-9 OLD ROAD, CLACTON-ON-SEA, ESSEX**

Our components are chosen by Technical Authors and Constructors throughout the World for their performance and reliability, every coil being inspected twice plus a final test and near spot-on alignment as a final check

Our General Catalogue showing full product range	...	16p
DTB4 Transistor & Valve circuitry for D.P. Coils	...	16p
DTB9 Valve Type Coil Pack Application circuitry	...	16p
MD.1 Decoder Circuitry for Stereo Reception	...	20p

All post paid, but please enclose S.A.E. with all other requests in the interests of retaining lowest possible prices to actual consumers





# -the lowest prices!

## 74 Series T.T.L. I.C.'s

NOW LOWER THAN EVER PRICES  
—GREATER RANGE

BI-PAK Semiconductors offer you the largest and most popular range of I.C.'s available at these EXCLUSIVE LOW PRICES. TTL Digital 74N Series fully coded, brand new. Dual in-line plastic 14 and 16 pin packages.

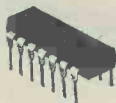

BI-PAK Order No.	Similar Types to:—Description	Price and qty. prices		
		1-24 £p	25-99 £p	100 up £p
BP00 = 7400	Quadruple 2-input NAND gate	0.23	0.20	0.15
BP01 = 7401	Quadruple 2-input positive NAND gate (with open collector output)	0.23	0.20	0.15
BP02 = 7402	Quadruple 2-input positive NOR gates	0.23	0.20	0.15
BP03 = 7403	Quadruple 2-input positive NAND gates (with open-collector output)	0.23	0.20	0.15
BP04 = 7404	Hex Inverters	0.23	0.20	0.15
BP10 = 7410	Triple 3-input positive NAND gates	0.23	0.20	0.15
BP13 = 7413	Dual 4-input Schmitt trigger	0.35	0.32	0.29
BP20 = 7420	Dual 4-input positive NAND gates	0.23	0.20	0.15
BP30 = 7430	8-input positive NAND gates	0.23	0.20	0.15
BP40 = 7440	Dual 4-input positive NAND buffers	0.23	0.20	0.15
BP41 = 7441	BCD to decimal nixie driver	0.87	0.77	0.67
BP42 = 7442	BCD to decimal decoder (4-10 lines, 1 of 10)	0.87	0.77	0.67
BP47 = 7447	BCD-to-ten-segment decoder/drivers (15V outputs)	1.40	1.30	1.20
BP50 = 7450	Expandable dual 2-input and-or-invert	0.23	0.20	0.15
BP51 = 7451	Dual 2-wide 2-input and-or-invert gates	0.23	0.20	0.15
BP63 = 7463	Quad 2-input expandable and-or-invert	0.23	0.20	0.15
BP64 = 7464	4-wide 2-input and-or-invert gates	0.23	0.20	0.15
BP60 = 7460	Dual 4-input expander	0.23	0.20	0.15
BP70 = 7470	Single-phase J-K flip-flop	0.35	0.32	0.29
BP72 = 7472	Master-slave J-K flip-flop	0.35	0.32	0.29
BP73 = 7473	Dual master-slave J-K flip-flop	0.43	0.40	0.37
BP74 = 7474	Dual D type flip-flop	0.43	0.40	0.37
BP75 = 7475	Quad latch	0.47	0.45	0.43
BP76 = 7476	Dual J-K with pre-set and clear	0.47	0.45	0.43
BP80 = 7480	Gated full adders	0.87	0.77	0.67
BP81 = 7481	16-bit read/write memory	1.35	1.25	1.15
BP82 = 7482	Quad full adder	1.30	1.20	1.00
BP83 = 7483	Quad 2-input exclusive or gates	0.87	0.77	0.67
BP86 = 7486	BCD decade counter	0.80	0.70	0.60
BP90 = 7490	8-bit shift registers	0.87	0.77	0.67
BP91 = 7491	Divide-by-twelve counters	1.21	1.00	0.87
BP92 = 7492	4-bit binary counters	0.87	0.77	0.67
BP93 = 7493	Dual entry 4-bit shift register	0.87	0.77	0.67
BP94 = 7494	4-bit up-down shift register	0.87	0.77	0.67
BP96 = 7496	6-bit parallel in parallel out shift-register	1.10	1.00	0.90
BP100 = 74100	8-bit bistable latches	1.75	1.65	1.56
BP118 = 74118	Monostable multivibrators	0.87	0.77	0.67
BP121 = 74121	BCD-to-decimal decoder/driver	0.87	0.77	0.67
BP141 = 74141	BCD-to-decimal decoder/drivers	1.80	1.70	1.60
BP145 = 74145	8-bit data selectors (with strobe)	1.40	1.30	1.20
BP151 = 74151	Dual 4-line-to-1-line data selectors/multiplexers	1.40	1.30	1.20
BP153 = 74153	Binary counter reversible	3.50	3.25	3.00

BP96 = 7496 6-bit parallel in parallel out shift-register  
BP100 = 74100 8-bit bistable latches  
BP118 = 74118 Monostable multivibrators  
BP121 = 74121 BCD-to-decimal decoder/driver  
BP141 = 74141 BCD-to-decimal decoder/drivers  
BP145 = 74145 8-bit data selectors (with strobe)  
BP151 = 74151 Dual 4-line-to-1-line data selectors/multiplexers  
BP153 = 74153 Binary counter reversible

## TTL INTEGRATED CIRCUITS

Manufacturers "Fall outs"—out of spec. devices including functional units and part function but classed as out of spec. from the manufacturers' very rigid specifications. Ideal for learning about I.C.'s and experimental work.

PAK No.	PAK No.	PAK No.
UIC00 = 12 x 7400N 50p	UIC42 = 6 x 7450N 50p	UIC80 = 6 x 7480N 50p
UIC01 = 12 x 7401N 50p	UIC60 = 12 x 7460N 50p	UIC82 = 6 x 7482N 50p
UIC02 = 12 x 7402N 50p	UIC31 = 12 x 7451N 50p	UIC83 = 6 x 7483N 50p
UIC03 = 12 x 7403N 50p	UIC68 = 12 x 7468N 50p	UIC86 = 6 x 7486N 50p
UIC04 = 12 x 7404N 50p	UIC70 = 8 x 7470N 50p	UIC90 = 5 x 7490N 50p
UIC05 = 12 x 7405N 50p	UIC72 = 8 x 7472N 50p	UIC92 = 5 x 7492N 50p
UIC10 = 12 x 7410N 50p	UIC73 = 8 x 7473N 50p	UIC93 = 5 x 7493N 50p
UIC20 = 12 x 7420N 50p	UIC74 = 8 x 7474N 50p	UIC94 = 5 x 7494N 50p
UIC40 = 12 x 7440N 50p	UIC76 = 8 x 7476N 50p	UIC95 = 5 x 7495N 50p
UIC41 = 5 x 7441AN 50p	UIC78 = 8 x 7478N 50p	UIC96 = 5 x 7496N 50p
	UICX1 = 25 x Ass'd 74's £1.50	

Packs cannot be split but 20 assorted pieces (our mix) is available as PAK UICX1. Every PAK carries our BI-PAK Satisfaction or money back GUARANTEE.

## BRAND NEW LINEAR I.C.'s—FULL SPEC.

Type No.	Case	Leads	Description	Price		
				1-24	25-99	100 up
BP 201C—8L201C	TO-5	8	G.P. Amp	68p	53p	45p
BP 701C—8L701C	TO-5	8	OP Amp	63p	50p	45p
BP 702C—8L702C	TO-5	8	OP Amp Direct OP	63p	50p	45p
BP 702—72702	D.I.L.	14	G.P. OP Amp (Wide Band)	53p	45p	40p
BP 709—72709	D.I.L.	14	High OP Amp	53p	45p	40p
BP 709P—1A709C	TO-5	8	High Gain OP Amp	53p	45p	40p
BP 711—1A711	TO-5	10	Dual comparator	68p	50p	45p
BP 741—72741	D.I.L.	14	High Gain OP Amp (Protected)	75p	60p	50p
1A 703C—1A703C	TO-5	6	R.F.-I.F. Amp	43p	35p	27p
TAA 263—	TO-72	4	A.F. Amp	70p	60p	55p
TAA 298—	TO-74	10	G.P. Amp	90p	75p	70p

## ANOTHER BI-PAK FIRST!

THE NEW SGS EA 1000  
AUDIO AMPLIFIER  
MODULE

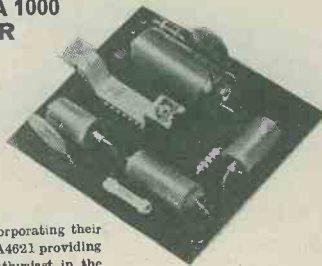

\* GUARANTEED  
NO LESS THAN  
3 WATTS RMS

Especially designed by S.G.S. incorporating their proven Linear I.C. Audio Amp. TA4821 providing unlimited applications for the enthusiast in the construction of radios, record players, Audio and Stereo units. Also ideal for inter-com systems, monitoring applications and phone answering machines. Other uses: portable applications where supply rails as low as 9V are of prime importance.

- Sensitivity 40 mV for 1 watt Voltage gain 40 dB but can be varied up to 73 dB for some applications.
- Signal to Noise Ratio 86 dB.
- Frequency response better than 50 Hz to 25 KHz for -3 dB.
- Normal supply Voltage 9-24V.
- Suitable for 8-16 ohm loads.
- Overall size 2" x 3" x 1".
- Typical Total Harmonic distortion at 1 Watt less than 1%.

Supply Voltage (Vs) = 24V 15 ohm load.

Module Tested and Guaranteed.

Qty 1-9 10-25  
Price each £2.63 £2.28

Larger quantities quoted on request. Full hook-up diagrams and complete technical data supplied free with each module or available separately at 10p each.

## NOTE THESE PRICES!

### I.C.'s DTL 930 SERIES LOGIC

Type No.	Function	Price		
		1-24	25-99	100 up
BP930	Expandable dual 4-input NAND	25p	20p	15p
BP932	Expandable dual 4-input NAND buffer	25p	23p	20p
BP933	Dual 4-input expander	25p	23p	20p
BP936	Expandable Hex Inverter	25p	23p	20p
BP936	Hex Inverter	25p	23p	20p
BP944	Dual 4-input NAND expandable buffer without pull-up	25p	23p	20p
BP946	Master-slave JK or RS	35p	32p	29p
BP948	Quad 2-input NAND	23p	20p	15p
BP951	Master-slave JK or RS	35p	32p	29p
BP951	Monostable	90p	85p	80p
BP962	Triple 3-input NAND	23p	20p	15p
BP9093	Dual Master-slave JK with separate clock	80p	75p	70p
BP9094	Dual Master-slave JK with separate clock	80p	75p	70p
BP9097	Dual Master-slave JK with Common Clock	80p	75p	70p
BP9099	Dual Master-slave JK Common Clock	80p	75p	70p

Devices may be mixed to qualify for quantity price. Larger quantity prices on application. (DTL 930 Series only.)

DTL (Diode Transistor Logic) INTEGRATED CIRCUITS manufacturers "Fall outs"—out of spec. devices including functional units and part functional but classed as out of spec. from the manufacturers' very rigid specifications. Ideal for learning about I.C.'s and experimental work.

PAK No.	PAK No.	PAK No.
UIC930 = 12 x 1A 930 .. 50p	UIC948 = 8 x 1A 948 .. 50p	UIC981 = 5 x 1A 981 .. 50p
UIC932 = 12 x 1A 932 .. 50p	UIC951 = 5 x 1A 951 .. 50p	UIC981 = 12 x 1A 981 .. 50p
UIC933 = 12 x 1A 933 .. 50p	UIC961 = 5 x 1A 961 .. 50p	UIC981 = 5 x 1A 981 .. 50p
UIC935 = 12 x 1A 935 .. 50p	UIC984 = 5 x 1A 984 .. 50p	UIC984 = 5 x 1A 984 .. 50p
UIC936 = 12 x 1A 936 .. 50p	UIC987 = 5 x 1A 987 .. 50p	UIC989 = 5 x 1A 989 .. 50p
UIC944 = 12 x 1A 944 .. 50p	UIC989 = 5 x 1A 989 .. 50p	UIC994 = 5 x 1A 994 .. 50p
UIC945 = 8 x 1A 945 .. 50p	UIC994 = 5 x 1A 994 .. 50p	UIC994 = 5 x 1A 994 .. 50p
UIC946 = 12 x 1A 946 .. 50p	UIC994 = 5 x 1A 994 .. 50p	UIC994 = 5 x 1A 994 .. 50p

Packs cannot be split but 25 Assorted Pieces (our mix) is available as PAK UIC9X. Every PAK carries our BI-PAK Satisfaction or money back guarantee. Data Booklet available for the BP930 Series. PRICE 13p

All prices quoted in new pence Giro No. 388-7006  
Please send all orders direct to warehouse and despatch department

# BI-PAK

P.O. BOX 6, WARE · HERTS

Postage and packing add 7p. Overseas add extra for airmail.  
Minimum order 50p. Cash with order please.

Guaranteed Satisfaction or Money Back

### REVERBERATION UNIT KIT

6 transistor réverberation chamber to which microphones, instruments, etc., may be connected for added dimensional effect. The output is suitable for most amplifiers and the unit is especially suitable for use with electronic organs. A ready-built spring and transducer assembly is used.



Complete easy-to-build kit, with constructional notes and circuits £7.50. Pre-drilled and printed case £1.70. All parts available separately. Send 5p for circuit and construction details.

### WAH-WAH PEDAL KIT



The Wilsic Wah-Wah pedal comprises a SELECTIVE AMPLIFIER MODULE KIT, containing all the components to build a two transistor circuit module, which may be used by the constructor for his own design or fitted to the FOOT VOLUME CONTROL PEDAL (as photo) converting

it to Wah-Wah operation. This pedal is in strong fawn plastic and fitted with output lead and screened plug. Selective amplifier module kit £1.75. Foot Volume control pedal £5.13. COMPLETE KIT £6.50. Add 38p for assembly of module.

### I-C STEREO AMP KIT

A new kit from Wilsic to build a hi-fi integrated circuit stereo amplifier. 3 watts per channel with full tone controls and attractive veneered cabinet, or may be built into plinth unit. Complete amp kit with stabilised power pack £21.45; with economy power pack £18.50. Cabinet kit: teak 73p, mahogany 66p. Full plans and detailed prices 10p.



Send 15p for latest catalogue with full details, circuits, etc., and SPECIAL DISCOUNT ORDER FORM.



**WILSIC ELECTRONICS LTD.**

6 COPLEY ROAD, DONCASTER, YORKS

## RSGB BOOKS FOR YOU

### VHF-UHF MANUAL

By G. R. Jessop, C.Eng., M.I.E.R.E., G6JP

2nd edition. Considerably enlarged and revised.

Transmitters, receivers and test equipment for use at vhf and uhf are all fully covered on a practical basis in this new edition. £1.80 post paid

### RADIO COMMUNICATION HANDBOOK

832 pages of everything in the science of radio communication. The Handbook's U.K. origin ensures easy availability of components. Complete coverage of the technical & constructional fields. A superb hard-bound volume. £3.50 post paid

### A GUIDE TO AMATEUR RADIO

By Pat Hawker, G3VA

Fourteenth edition. 100 pages.

The new edition of this indispensable aid to all who want to know more about amateur radio. Designed to assist the newcomer to this unique hobby. Revised and expanded. 47p post paid

These are three of a complete range of technical publications, log books and maps, all obtainable from:

**RADIO SOCIETY OF GREAT BRITAIN**

35 DOUGHTY STREET, LONDON, WC1N 2AE

# LATEST BOUND VOLUME No. 23

of

## "The Radio Constructor" FOR YOUR LIBRARY

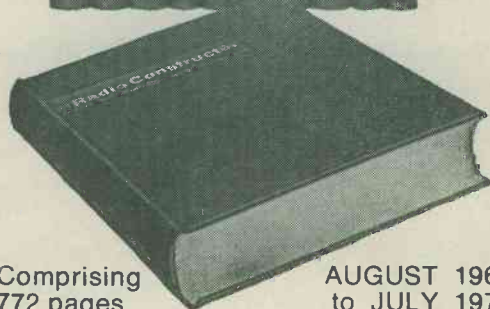

Comprising 772 pages plus index

AUGUST 1969 to JULY 1970

**PRICE £1.88 Postage 28p**

### BOUND VOLUME NO. 24

OF

### "THE RADIO CONSTRUCTOR"

The bound edition of the volume just completed, No. 24, August 1970 to July 1971, will be available in early October.

**PRICE £2.00 Postage 28p**

We regret all earlier volumes are now completely sold out.

Available only from

**DATA PUBLICATIONS LTD.,**  
57 MAIDA VALE, LONDON, W9 1SN



# BI-PRE-PAK LIMITED

## FULLY TESTED AND MARKED

AC107 .15	OC140 .17
AC126 .13	OC170 .23
AC127 .17	OC171 .23
AC128 .13	OC200 .25
AC176 .25	OC201 .25
AF137 .15	2G301 .13
AF139 .13	2G303 .13
AF186 .37	2N171 .50
AF239 .37	2N1302-3 .20
BC154 .25	2N1304-5 .25
BC171	2N1306-7 .30
= BC107 .13	2N1308-9 .35
BC172	BC113 .10
= BC108 .13	Power
BF194 .15	Transistors
BF274 .15	OC20 .50
BFY50 .20	OC23 .30
BSY25 .37	OC25 .25
BSY26 .13	OC26 .25
BSY27 .13	OC28 .30
BSY28 .13	OC35 .25
BSY29 .13	OC36 .37
BSY95A .13	AD149 .30
OC41 .13	AUY10 1.25
OC44 .13	2N3055 .63
OC45 .13	25034 .25
OC71 .13	Diodes
OC72 .13	AAV42 .10
OC73 .17	OA95 .09
OC81 .13	OA79 .09
OC81D .13	OA81 .09
OC139 .13	IN914 .09

## CLEARANCE LINES

SL403D Audio Amp. ....	1-10	10-50	50+
IC. 709C Linear Opp. Amp. ....	2.00	1.95	1.80
A.E.I. Fully marked and tested Gates .....	50p	40p	35p
A.E.I. Fully marked and tested Flipflops .....	25p	22p	20p
OC71/72, Fully tested, unmarked .....	5p	5p	4p
Matched Sets, 1-OC44, 2-OC45. Per set .....	25p	20p	15p
Matched Sets, OC45, 1st and 2nd I.F. Per set .....	15p	12p	10p
TIC45 Thyristors .6A, 60V, Texas .....	15p	15p	12p
OA47 Gold bonded Diodes, marked and tested .....	3p	3p	2p
1W Zener Diodes 6.8, 7.5, 24, 27, 30 and 43 volts .....	5p	4p	3p
10W Zener Diodes 7.5, 11, 13, 20 and 100 volts .....	20p	17p	15p
Micro Switches, S/P, C/O, popular size .....	25p	20p	15p
1 Amp. Bridge Rectifiers, 25V, RMS .....	25p	22p	20p
1 Amp. Plastic Rectifiers. These are voltage, reverse polarity and other rejects from the BY127 range. Ideal for low voltage Power Units, etc. Price: £1 per 100.			

COLOUR T.V. LINE OUTPUT TRANSFORMERS  
Designed to give 25KV when used with PL509 & PY500 valves. As removed from colour receivers at the factory.  
**ONLY £1 each.** Post and Packing .25

## NEW TESTED & GUARANTEED PAKS

B2	4	Photo Cells, Sun Batteries. 0.3 to 0.5V, 0.5 to 2mA.	50p
B79	4	IN4007 Sil. Rec. diodes, 1,000 PIV 1 amp plastic	50p
B81	10	Reed Switches, mixed types large and small	50p
B99	200	Mixed Capacitor. Postage 13p. Approx. quantity, counted by weight	50p
H4	250	Mixed Resistors. Postage 10p. Approx. quantity, counted by weight	50p
H7	40	Wirewound Resistors. Mixed types and values. Postage 8p	50p
H8	4	BY127 Sil. Recs. 1000 PIV. 1 amp. plastic	50p
H9	2	OC71 Light Sensitive Photo Transistor	50p
H12	20	NKT155/259 Germ. diodes. brand new stock clearance	50p
H18	10	OC71/75 uncodded black glass type PNP Germ.	50p
H19	10	OC81/81D uncodded white glass type PNP Germ.	50p
H28	20	OC200/1/2/3 PNP Silicon uncodded TO-5 can	50p
H29	20	OA47 gold bonded diodes coded MCS2	50p

**FREE!** Packs of your own choice up to the value of .50 with orders over £4.

## OUR VERY POPULAR 3p TRANSISTORS

FULLY TESTED & GUARANTEED.

TYPE "A" PNP Silicon alloy, metal TO-5 can. 2S300 type, direct replacement for the OC200/203 range.  
TYPE "B" PNP Silicon, plastic encapsulation, low voltage but good gain, these are of the 2N3702/3 and 2N4059/62 range.  
TYPE "E" PNP Germanium AF or RF - please state on order. Fully marked and tested.  
TYPE "F" NPN Silicon, plastic encapsulation, low noise amplifier, of the 2N3707/8, 9, 10, 11 range

## BULK BUYING CORNER

NPN/PNP Silicon Planar Transistors, mixed untested, similar to 2N706/6A/8, BSY26-29, BSY95A, BCY70, etc.  
**£4.25 per 500. £8.00 per 1,000.**

Silicon Planar NPN Plastic Transistors, untested, similar to 2N3707-11, etc.  
**£4.25 per 500. £8.00 per 1,000.**

Silicon Planar Diodes, DO-7 Glass, similar to OA200/202, BAY31-36.  
**£4.50 per 1,000.**

NPN/PNP Silicon Planar Transistors, Plastic TO-18, similar to BC113/4, BC153/4, BF153/160, etc.  
**£4.25 per 500. £8.00 per 1,000.**

OC44, OC45 Transistors, fully marked and tested.  
**500 plus at 8p each. 1,000 plus at 6p each.**

OC71 Transistors, fully marked and tested.  
**500 plus at 6p each. 1,000 plus at 5p each.**

3823E Field effect Transistors. This is the 2N3823 in plastic case.  
**500 plus, 13p each. 1,000 plus, 10p each.**

1 Amp. Miniature Plastic Diodes  
IN4001 500+ 3p each. 1,000+ 3p each.  
IN4004 500+ 5p each. 1,000+ 4p each.  
IN4006 500+ 6p each. 1,000+ 5p each.  
IN4007 500+ 8p each. 1,000+ 7p each.

## NEW UNMARKED UNTESTED PAKS

B80	8	Dual Trans. Matched O/P pairs NPN, Sil. in TO-5 can.	.50
B83	200	Trans. Makers rejects. NPN/PNP. Sil. & Germ.	.50
B84	100	Silicon Diodes DO-7 glass equiv. to OA200, OA202.	.50
B86	50	Sil. Diodes sub. min. IN914 & IN916 types.	.50
B88	50	Sil. Trans. NPN, PNP. equivalent to OC200/1, 2N706A, BSY95A, etc.	.50
B60	10	7 Watt Zener Diodes. Mixed voltages.	.50
H6	40	250mW. Zener Diodes DO-7 min. Glass Type.	.50
H10	25	Mixed volts 1½ watt Zeners. Top Hat type.	.50
B66	150	High quality Germ. Diodes. Min. glass type	.50
H15	30	Top Hat Silicon Rectifiers. 750mA. Mixed volts.	.50
H16	8	Experimenters' Pak of Integrated Circuits. Data supp.	.50
H20	20	BY126/7 type Silicon Rectifiers. 1A. plastic to 1,000v	.50

## F.E.T. PRICE

## BREAKTHROUGH !!!

This field effect transistor is the 2N3823 in a plastic encapsulation coded 3823E. It is also an excellent replacement for the 2N3819.  
Data sheet supplied with device.  
1-10 - 30p, 10-50 - 25p, 50 plus - 20p.

MAKE A REV. COUNTER for your Car. The 'TACHO BLOCK'. This encapsulated block will turn any 0-1mA meter into a perfectly linear and accurate rev. counter for any car. **£1 each**

FREE CATALOGUE AND LISTS for:-

ZENER DIODES  
TRANSISTORS, RECTIFIERS  
FULL PRE-PAK LISTS  
& SUBSTITUTION CHART

MINIMUM ORDER .50 CASH WITH ORDER PLEASE. Add .10 post and packing per order. OVERSEAS ADD EXTRA FOR POSTAGE.

P.O. RELAYS **8 FOR**  
Various Contacts and Coil Resistances. No individual selection. Post and Packing .25 **£1**

**FREE! A WRITTEN GUARANTEE WITH ALL OUR TESTED SEMICONDUCTORS**

**BI-PRE-PAK LTD** DEPT. C, 222-224 WEST ROAD, WESTCLIFF-ON-SEA, ESSEX  
TELEPHONE: SOUTHEND (0702) 46344



# 3 WAYS

HOME RADIO (Components) LTD.  
 Dept. RC, 234-240 London Road,  
 Mitcham CR4 3HD. 01-648 8422

## of obtaining components quickly & easily

# 1

**CALL AT No. 240  
 London Rd., Mitcham**

If you live within easy reach of Mitcham or are in the area at any time do call on us. We are almost opposite Mitcham Baths. We open 9 a.m. every weekday. On Wednesdays we close 1 p.m. and all other days, including Saturdays, 5.30 p.m. On Saturdays we have extra staff to deal with queries. We carry a vast stock of components, and 999 times out of a 1,000 we can immediately lay our hands on the particular item required.

# 2

**JOIN OUR CREDIT  
 ACCOUNT SERVICE**

We began our Credit Account Service about 18 months ago and it has proved extremely popular. Little wonder! Our customers find it a very simple and convenient way of purchasing all their radio and electronic needs. We supply pre-paid envelopes and order forms and no matter how many orders you send us you make only one payment per month. There are several other advantages with our Credit Account Service. Please write or phone for details.

The price of 70p applies only to catalogues purchased by customers in the U.K. and the BFPO addresses.

# 3

and  
**ORDER BY MAIL  
 OR TELEPHONE**

Although we are kept busy selling "over the counter" we supply even more by Mail Order. You can telephone any time of day or night, Sundays included. If you ring out of office hours a recording machine takes your message for us to deal with as soon as we open shop again. Our number is 01-648 8422. If you wish to order by post our address is in the panel at the top of the page. We deal with all orders promptly.



**WHICHEVER WAY  
 YOU CHOOSE you  
 need the Home Radio  
 Catalogue**

In its 315 pages are listed over 8,000 components, over 1,500 of them illustrated. Each copy contains 10 Vouchers, each worth 5p when used as instructed. Free Supplements are supplied regularly to keep you up-to-date. The Catalogue costs 50p over the counter, or 70p including postage and packing.

**Post this Coupon with  
 Chaque or P.O. for 70p**

Please write your Name and Address in block capitals

Name .....

Address .....



**HOME RADIO (Components) LTD.  
 Dept. RC, 234-240 London Road, Mitcham CR4 3HD**

THE RADIO CONSTRUCTOR



# THE Radio Constructor



Incorporating THE RADIO AMATEUR

AUGUST 1971

Vol. 25 No. 1

## CONTENTS

Published Monthly (1st of Month)  
First Published 1947

Editorial and Advertising Offices  
57 MAIDA VALE LONDON W9 1SN

Telephone 01-286 6141      Telegrams  
Databux, London

© Data Publications Ltd., 1971. Contents may only be reproduced after obtaining prior permission from the Editor. Short abstracts or references are allowable provided acknowledgement of source is given.

Annual Subscription: £2.70 (U.S.A. and Canada \$6) including postage. Remittances should be made payable to "Data Publications Ltd." Overseas readers please pay by cheque or International Money Order.

*Technical Queries.* We regret that we are unable to answer queries other than those arising from articles appearing in this magazine nor can we advise on modifications to equipment described. We regret that such queries cannot be answered over the telephone; they must be submitted in writing and accompanied by a stamped addressed envelope for reply.

*Correspondence* should be addressed to the Editor, Advertising Manager, Subscription Manager or the Publishers as appropriate.

*Opinions* expressed by contributors are not necessarily those of the Editor or proprietors.

*Production.*—Letterpress.

F.E.T. REFLEX RECEIVER	10
AN ELECTROSTATIC GENERATOR	12
TRADE NEWS	14
NOTES ON SEMICONDUCTORS – 6	15
BINARY NIM (Suggested Circuit No. 249)	16
THE TRANSMATCH	20
ALTERNATIVE MULTI-VOLTAGE CIRCUIT	22
PROJECT MOONRAY	23
NEWS AND COMMENT	24
AERIAL DISTRIBUTION BOARD	26
NOW HEAR THESE	28
DIODE AND TRANSISTOR TESTERS	29
A.C./D.C. MYSTERY BULB	30
THE BANDMASTER	32
CURRENT SCHEDULES	39
COUPLING CAPACITORS CAUSES COMPLICATIONS	40
LATIN AMERICAN QUEST – 5	43
IN YOUR WORKSHOP	46
IN BRIEF	53
BOOK REVIEWS	54
RADIO TOPICS	55
LATE NEWS	57
LAST LOOK ROUND	57
RADIO CONSTRUCTOR'S DATA SHEET No. 53 (Time Frequency Table)	iii

Published in Great Britain by the Proprietors and Publishers, Data Publications Ltd, 57 Maida Vale, London, W9 1SN.

The Radio Constructor is printed by Kent Paper Company Ltd, London and Ashford, Kent.

SEPTEMBER ISSUE WILL BE  
PUBLISHED ON SEPTEMBER 1st

# F.E.T. REFLEX RECEIVER

by

A. W. WHITTINGTON

Adding an f.e.t. input stage to a well-trying reflex circuit improves selectivity and offers a wide latitude in ferrite aerial design

THE CIRCUIT TO BE DESCRIBED IS A MODIFICATION to a very successful *Radio Constructor* design, and it takes advantage of an f.e.t. to increase selectivity.

Anyone who has built the silicon reflex circuit described by G. W. Short in the January 1968 and September 1969 issues\* will have been amazed at the sensitivity of this receiver. The writer has carried out a number of experiments with the circuit, including the use of coils for coverage up to 6MHz.

Since f.e.t.'s are now available to amateur constructors at reasonable prices, it was decided to employ one of these devices to provide an aerial input stage preceding the basic reflex circuit due to G. W. Short. The chief advantages conferred by an f.e.t. are low noise, high input impedance and low cross-modulation. The high input impedance is of particu-

lar importance here since there is then less damping of the aerial tuned circuit, which becomes capable of offering greater selectivity. Also, the use of an f.e.t. allows a panel-controlled reaction circuit to be incorporated.

## MODIFIED CIRCUIT

The circuit of the complete receiver appears in Fig. 1, the circuitry to the right of C4 which incorporates TR2 and TR3 being based on the receiver design previously published. In the original, D1 was returned to the earthy end of a coupling winding on the aerial ferrite rod, this winding being by-passed to the lower supply rail via a 0.01 $\mu$ F capacitor. The non-earthly end of the coupling winding connected to the base of what is now TR2. In the present circuit the diode couples direct to the base of TR2.

The f.e.t., TR1, is a 2N3819 operated in the common source mode. Gate-source bias is provided by R2 and C3. The ferrite rod aerial tuned circuit

\*G. W. Short, 'Silicon Transistor Reflex T.R.F.', *The Radio Constructor*, January 1968; 'Milliwatt' Silicon Reflex T.R.F. Receiver', *The Radio Constructor*, September 1969.

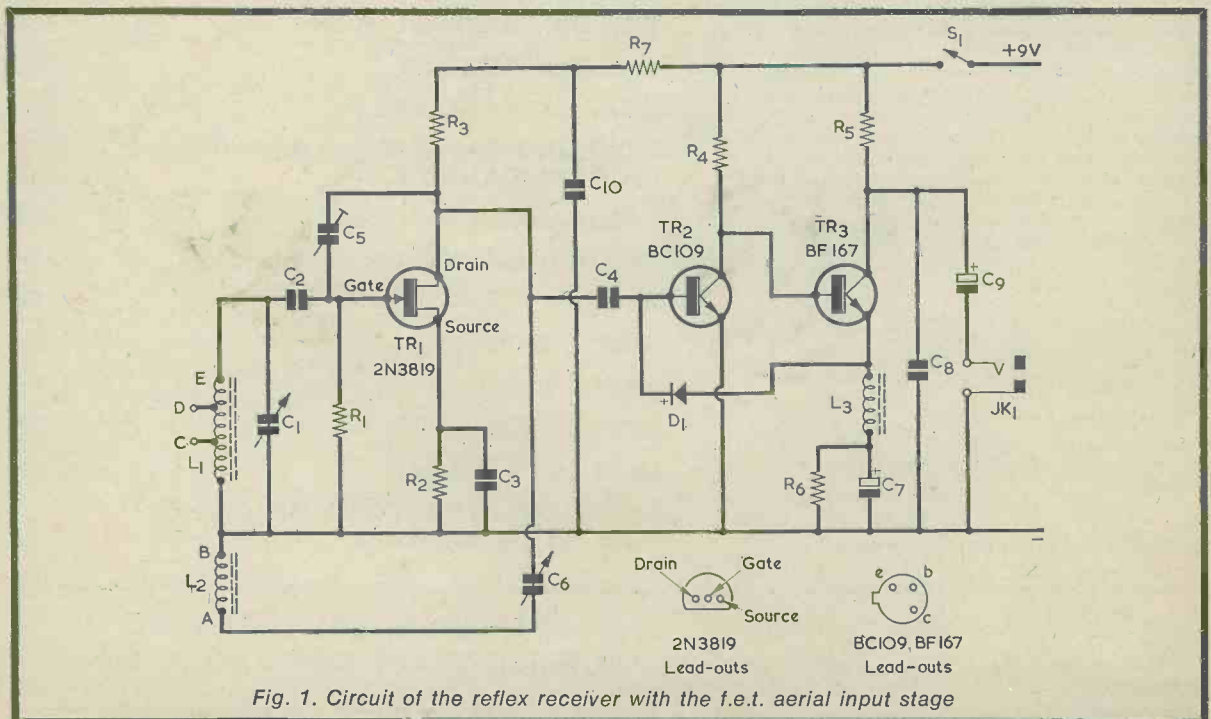



is applied directly to the gate via C2. The relatively low value drain load resistor, R3, provides adequate matching to TR2. Regeneration is obtained from the drain and is controlled by capacitor C6. Trimmer C5 is incorporated to provide neutralisation.

The aerial coil is wound on a 4in. length of  $\frac{3}{8}$ in. diameter ferrite rod as shown in Fig. 2. The winding wire was Radiospares 'Miniature' p.v.c. covered flexible wire with a 7/0.0048 (or 7/40 s.w.g.) stranded core and an insulation wall thickness of 0.01in. Similar thin p.v.c. covered connecting wire should work equally well. Start  $\frac{1}{2}$ in. from one end and close-wind directly onto the rod. The section of the coil between points A and B is the regeneration winding, and that between points B and E the tuned winding. This gives a range of 2.5MHz to 620kHz with the tuning capacitor specified. Taps C and D can be used for the connection of a short aerial, if desired. This should only be a few feet in length and is applied via a 100pF variable capacitor, the latter being adjusted for best results.

### CONSTRUCTION

The author's prototype was assembled on a perforated matrix board of 0.15in. hole pitch measuring 7in. long by 2 $\frac{1}{2}$ in. wide. Layout follows the circuit diagram, with the tuning capacitor at the left and the on-off switch to the right. The ferrite rod lies longitudinally at the back and the negative supply rail wire along the front of the board. There is 1in. spacing between the centre lines of the core of L3 and the ferrite aerial rod, the two cores being parallel with each other. Components are connected by means of terminal pins passed through the holes in the board as required. The two variable capacitors, the headphone output jack and the on-off switch are mounted on a small Paxolin front panel. Tuning capacitor C1 is fitted with a slow-motion drive.

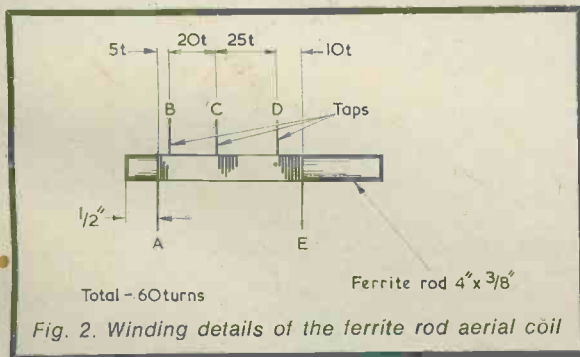

Fig. 2. Winding details of the ferrite rod aerial coil

To avoid damage to the f.e.t. resulting from static voltages on soldering irons, etc., this device must be fitted in a transistor holder. All connections in the receiver, including those to the holder, are soldered before the f.e.t. is inserted. It is necessary to drill out the matrix board in order that it may take the transistor holder. If desired, TR2 and TR3 can also be fitted in transistor holders, whereupon it becomes possible to check a number of transistors for operation in the receiver.

When the assembly and wiring have been completed and carefully checked, the current consumption from the 9 volt battery should be measured.

## COMPONENTS

### Resistors

(All  $\frac{1}{4}$  watt 10%)

R1	2.2M $\Omega$
R2	3.3k $\Omega$
R3	1.8k $\Omega$
R4	12k $\Omega$
R5	3.9k $\Omega$
R6	680 $\Omega$
R7	220 $\Omega$

### Capacitors

C1	365pF variable, Type 01 (Jackson Bros.)
C2	100pF silver-mica
C3	0.022 $\mu$ F paper or plastic foil
C4	220pF silver-mica
C5	30pF trimmer
C6	300pF variable, solid dielectric
C7	100 $\mu$ F electrolytic, 3V wkg.
C8	0.022 $\mu$ F paper or plastic foil
C9	8 $\mu$ F electrolytic, 10V wkg.
C10	0.1 $\mu$ F paper or plastic foil

### Inductors

L1, L2	Home-wound aerial coil on ferrite rod, 4in. by $\frac{3}{8}$ in. dia. (see text)
L3	2.5mH r.f. choke Type CH1 (Repanco)

### Semiconductors

TR1	2N3819
TR2	BC109
TR3	BF167
D1	OA81

### Switch

S1	s.p.s.t. toggle
----	-----------------

### Socket

JK1	Headphone jack
-----	----------------

### Miscellaneous

Headphones, 2,000 $\Omega$ to 4,000 $\Omega$ , with jack plug
Slow-motion drive
2 knobs
Material for chassis, front panel, etc.

This should be of the order of 2 to 3mA. A strong local signal at the high frequency end of the band is then tuned in and C5 adjusted to eliminate any instability that may be present. Some r.f. feedback is provided by the inductive coupling between L3 and the ferrite rod. If necessary, this feedback may be adjusted by rotating L3.

### TRAWLER BAND

Because the tuned circuit only has two connections it is possible to experiment with a wide variety of different aerial inductances.

The 'trawler band' can offer hours of interesting listening for those who live in coastal locations. This band was tuned in with an aerial coil wound on a 6in. length of  $\frac{3}{8}$ in. diameter ferrite rod, and employing 40 turns of 0.032in. (21 s.w.g.) solid core p.v.c. covered connecting wire. The winding commences about  $\frac{1}{2}$ in. from one end and the turns should be spread over the greater length of the rod. An extra four turns for regeneration will be adequate. An aerial, of 2ft. only, may be connected to the non-earthly end of the tuned coil.

# AN ELECTROSTATIC GENERATOR

D. P. NEWTON, B.Sc., Grad.Inst.P.

Those who are interested in the history of electricity can journey back in time by making an electrostatic generator of the type used in the days of Davy and Faraday. Construction is not too difficult, the generator consisting basically of a rotating glass cylinder with a leather pressure-pad

**B**EFORE THE TIME OF THE VOLTAIC CELL AND THE production of continuous, large electric currents by batteries, the word 'electricity' usually referred to the phenomenon of static electricity. The electrical properties of fur, glass and sulphur were known to the Ancient Greeks, and few schoolchildren nowadays would not know how a plastic comb or pen could be made to pick up small pieces of paper, or how a balloon may be made to stick to the hand, or even how to make hair stand on end with a sheet of plastic.

Electrostatics is an attractive subject because of the ease with which static electricity can be produced and the surprising, and even spectacular, results that are possible. This was no less the case at the beginning of the nineteenth century, when few laboratories were without means of producing static electricity at a fairly steady rate. The machines were often made as much for entertainment as for research, as is seen in the following account by John Cuthbertson,\* written at the end of the eighteenth century.

\* Taken from 'Practical Electricity and Galvanism' by John Cuthbertson, Philosophical instrument maker, London. J. Callow 1807. (Edited.)

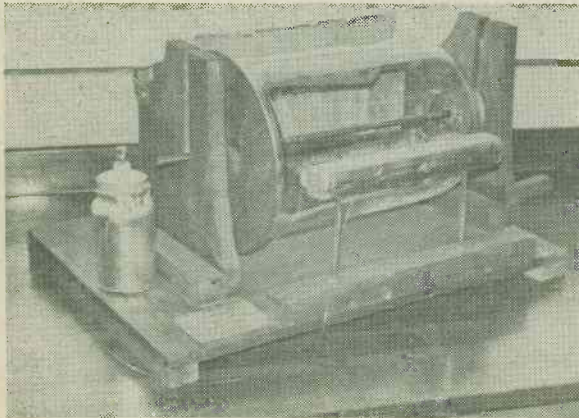

The electrostatic generator. The charge is taken from the rotating glass cylinder by the brushes in the foreground

*'The electrified person in the former experiment being a lady, may challenge any gentleman, not acquainted with the experiment, that he will not be able to kiss her in that situation, although she may incline to meet him. If he accepts the challenge, and the machine turn while they are inclining their heads to kiss each other, provided their clothes do not touch before their lips meet, a spark of fire will fly from the lady to the gentleman, which will be sure to make him draw back, without accomplishing his design.'*

Various, ingenious devices had succeeded the electrophorus, from a hand-rotated sphere of sulphur with a fur or silk friction pad to the counter-rotating discs of the Wimshurst machine. Today, the Van de Graaf machine still finds a use in producing high voltages for work in nuclear physics.

## CONSTRUCTION

Most of the earlier electrostatic generators are fairly easy to construct, the electricity being produced by a friction pad and removed by a set of points. In a typical instance, a solid glass cylinder would be rotated against a rubber and leather pressure pad. This pad held a silk flap in place and the charge produced by friction was collected by a series of points at the opposite side. The charge was stored on a sausage-shaped conductor.

The same basic principle is followed in the home-constructed electrostatic generator now to be described, with the exception that the silk is omitted and a leather pad presses against the glass on its own. The reason for this omission is that 'oiled silk' was used in the early generators but this is now expensive. Several substitute materials were tried, these consisting of ordinary silk, cellophane and various plastics, but the increase in electrostatic charge did not merit the extra work in fitting them. Leather against glass gives satisfactory results. The leather may be easily obtained from shoe repairers' as an offcut. Also, some general stores, such as Woolworth's, sell it.

As may be seen from Figs. 1 and 2, a bell jar (obtainable from chemists) measuring 15in. high

THE RADIO CONSTRUCTOR



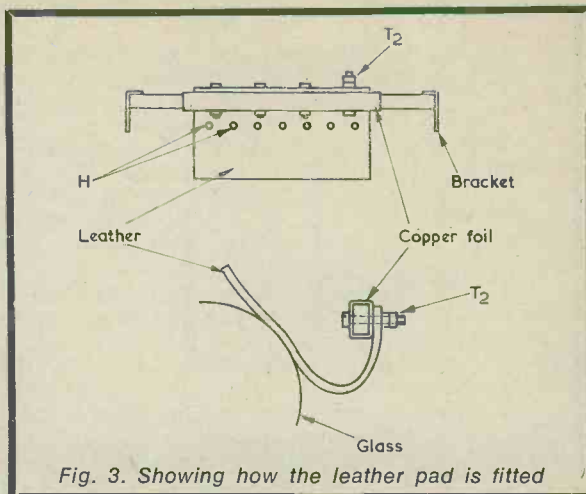
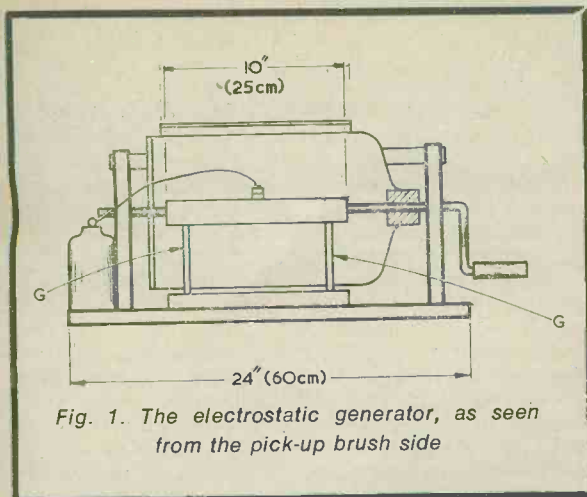

by 9in. in diameter (38 cm by 23 cm), functions as the glass cylinder. A plywood disc, W, is fitted to the open base of the bell jar, a hole being drilled in this to take a metal rod, of approximately  $\frac{3}{4}$ in. diameter, which serves as axle and handle. A rubber bung holds the rod in place at the neck of the bell jar. This axle drops into vertical slots in the wooden supports and a wooden handle is fitted to make turning easier. Bolted across the back of the supports is the holder for the pressure pad (AA in Fig. 2), which is shown in detail in Fig. 3. A layer of copper foil is tacked around a wooden bar then a piece of leather measuring 12 in. by 6 in. by  $\frac{1}{4}$ in. (30cm by 15cm by 0.5cm) is bolted into place as shown. The terminal T2 is used as one bolt and should make a good contact with the copper. Brackets hold the bar in place so that the leather exerts a pressure on the cylinder as in Fig. 3. This pressure can be so great that the cylinder may not turn. It is decreased by drilling holes, H, along the length of the leather.

On the pick-up side, BB in Fig. 2, the collection of the charge is made by four small suede-brushes. The brass wire of these brushes is ideal for the purpose. Each brush is linked together by a copper

wire, as in Fig. 4, and the charge delivered to terminal T1 on the wooden bar. This bar should have the corners rounded and be completely covered with aluminium foil. No sharp edges should remain, as these quickly dissipate the charge. The bar itself is supported on two solid glass rods, G, which insulate it from the apparatus. Note that the brushes do not need to touch the glass cylinder to pick up the charge but should be fairly close.

When the cylinder is rotated, a small spark can be taken from the pick-up with the finger. The wooden handle may be lubricated with graphite. Terminal T2 may be earthed to improve the effect.

### LEYDEN JAR

The generator is now to be improved by the addition of a Leyden jar, the forerunner of the modern capacitor. A jar of about the dimensions given in Fig. 5 is lined inside and outside with aluminium foil ('silver' paper) to the height indicated. These two layers are separated by the glass and the outer will be earthed by virtue of its contact with the bench or table. The mouth of the jar is plugged with a good insulator (many plastics or wax will

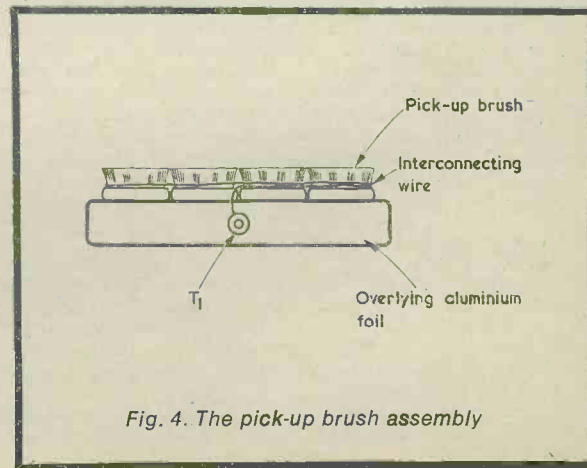
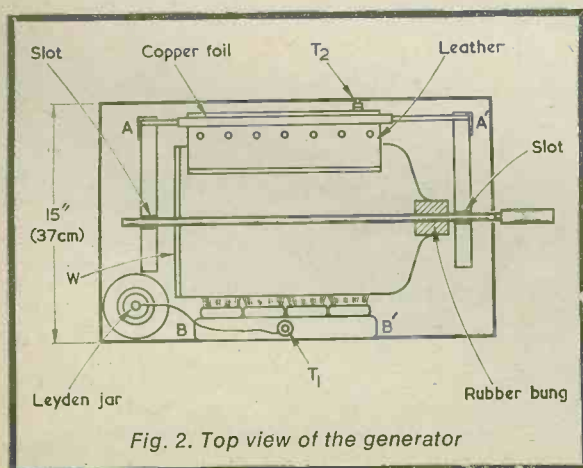
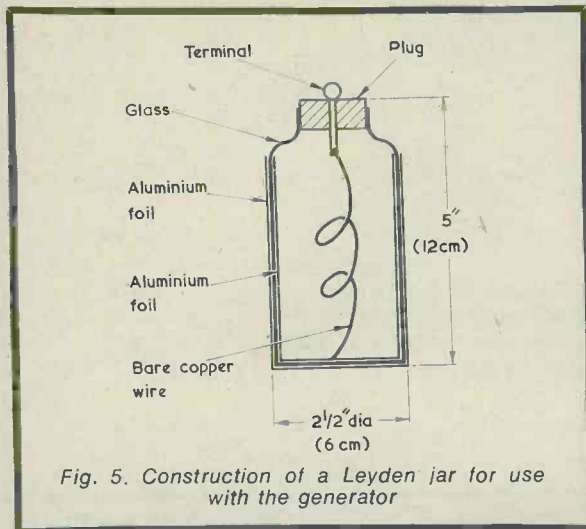

Fig. 2. Top view of the generator

Fig. 4. The pick-up brush assembly



serve) and the terminal screwed through. Note that the top should be rounded to prevent loss of charge. A wire from the base of the terminal rests on the inner layer of foil.

The jar is connected to T1 as in Figs. 1 and 2, ensuring that the ends of the wire do not protrude to provide a leakage point. When the cylinder is rotated, the charge is now mainly stored in the Leyden jar. By touching the outer layer of foil and the terminal with the finger and thumb of one hand the increase in charge will be noted.

*Great care is needed when operating electrostatic generators of this nature as quite considerable shocks can be obtained under some conditions.*

The generator needs to be operated in a dry room because the voltage is so high that a damp atmosphere allows the charge to leak away.

Modern electricity has come a long way since the days of 'vitreous' and 'resinous' electricity and yet electrostatics is still attractive. Somehow, the element of surprise can never quite be dispelled - so much can be obtained from so little. ■

## TRADE NEWS

### NEW INSTANT FASTENING SYSTEM

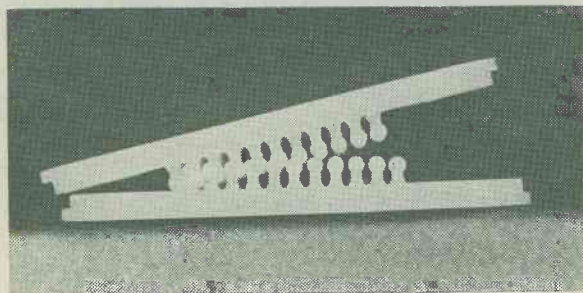

Hedlok fasteners, used to attach speaker grilles to larger speakers, are simply stapled to wood.

This magnified photograph shows two Hedlok fasteners being interlocked. The engagement is positive and instantaneous.

Hedlok fasteners, a new reclosable fastening medium made by 3M Company, will be available in the U.K. from June 1971. Invented and tested in America, these fasteners consist of interlocking twin parts which are pushed together and pulled apart without tools.

Hedlok fasteners, available in several pre-determined holding strengths, do not require exact alignment or positioning. They automatically compensate for dimensional changes in fibre board or cloth components. As blind attachment is possible, less skilled labour is needed at various stages of production.

Hedlok fasteners are moulded from either acetal or nylon. Both materials offer distinct advantages. Nylon fasteners have the best high-temperature properties, permitting continuous use up to 250°F and intermittent use up to 350°F. They are sewn and stapled more easily than acetal and are tougher for high-impact repeated use applications.

Acetal fasteners are harder and stiffer, and, therefore, stronger than nylon parts. They are, unlike nylon fasteners, virtually unaffected by prolonged under water

exposure. The recommended upper temperature use of the acetal fasteners is 200°F with intermittent exposure to 225°F. They are preferable where below-zero temperature engagements are needed.

Advantages claimed for the Hedlok fasteners are vibration resistance, corrosion resistance and solvent resistance.

Samples and further details are available from 3M Company, 3M House, Wigmore Street, London W1A 1ET.

### D.I.Y. CIRCUIT BOARDS

Vero Electronics Ltd., of Chandlers' Ford, Hampshire, have recently introduced a range of D.I.Y. Boards compatible with their Card Frame System 3, these boards have been introduced to provide a quick easy method of producing a plug-in circuit board for laboratory use. The basic board consists of a single-sided fully copper-clad blank which is provided with a certain number of accurately positioned contact fingers at one end. The circuit required is drawn on the blank with a special Dalo marker, Vero part number 14021. Once dry the ink provides a resist which enables the board to be etched to the layout required. Component mounting holes can then be drilled and a suitable flux sprayed onto the board. The board is then ready for use, without the need for extremely accurate etching facilities or gold plating equipment.

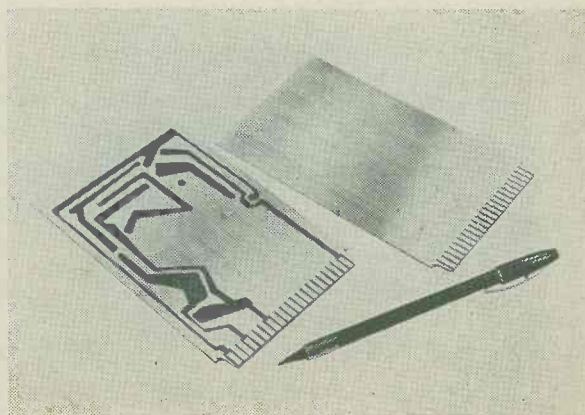

THE RADIO CONSTRUCTOR





# NOTES ON SEMICONDUCTORS

## THE METER BOOSTER

by  
**PETER WILLIAMS**

**An ultra-simple circuit which raises voltmeter input resistance to valve voltmeter standards**

**D**O YOU EVER LOOK LONGINGLY AT THE high-performance (and sometimes high-cost) electronic voltmeters with multi-megohm input resistances? The obvious answer is to make your own - but of course the circuits are complicated, special transistors are needed and so on! This is not quite true. If you need to measure voltages in transistor circuits and are content to have a sensitivity of, say, 5V and upwards, then a stable high-resistance voltmeter can be built using a normal multi-meter and one silicon planar transistor.

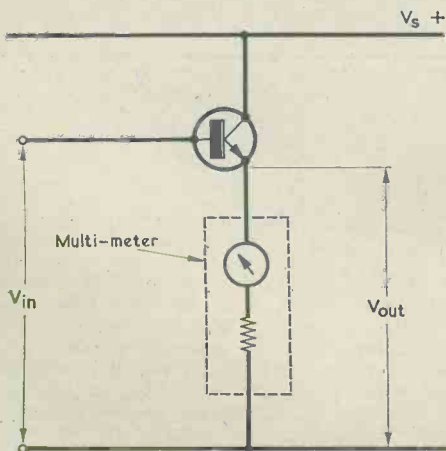

$$V_s > V_{out \text{ max.}}$$
$$V_{out} = V_{in} - V_{be}$$

Fig. 1. Circuit of the Meter-Booster. The multi-meter is switched to an appropriate voltage range. The supply battery should be 'floating' with respect to earth and any other external connections

### INPUT VOLTAGES

Of course there are snags. The minimum voltage to which the circuit will respond is about 0.5 volt, and the output is approximately half a volt less than the input throughout. Because this figure is fairly constant, simply shifting the mechanical offset on the meter movement temporarily corrects for this, for voltages of half a volt and above. Apart from this, the error is likely to be less than those of meter movement and multipliers. The 'circuit', such as it is, is shown in Fig. 1. Using a multimeter of  $50\mu\text{A}$  basic sensitivity, and a high-gain, low-current transistor, the maximum input current to the base of the transistor could easily be less than  $1\mu\text{A}$ . Now using the meter on its 10 volt range the input resistance would be  $10\text{M}\Omega$ , comparable to that obtained with valve voltmeters. Apart from the basic 500mV or so 'dead-space' needed to bring the transistor into conduction, the accuracy is basically that of the meter itself with scales selected directly on the meter. The input resistance is boosted by the current gain of the transistor.

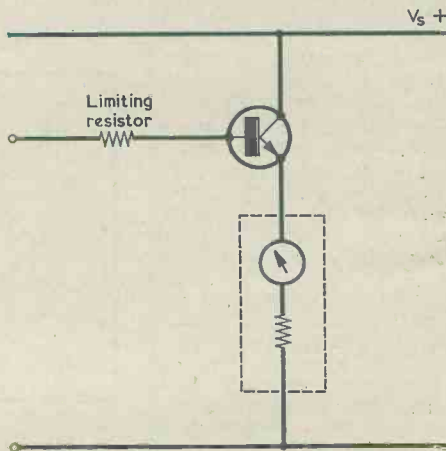
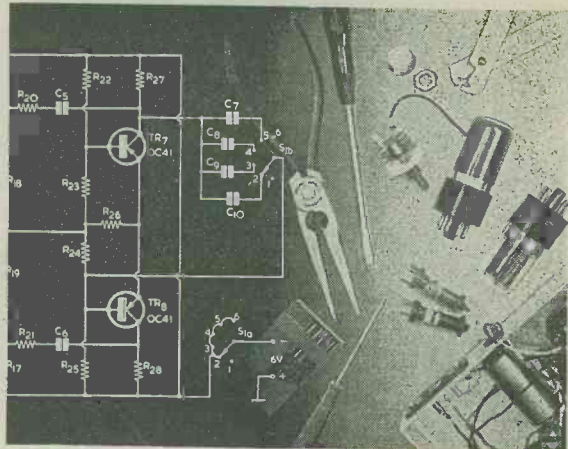

Fig. 2. It is advisable to include a limiting resistor in the base circuit of the transistor. The resistor should have the highest value possible without reducing accuracy excessively

The simple precautions to be taken are (a) to limit the input voltage to less than the breakdown voltage for the transistor, (b) to limit the input voltage to less than the supply voltage, (c) to ensure that the input voltage has correct polarity (which would in any case be necessary with the meter on its own), (d) preferably to include a series limiting resistor in the base circuit -  $10\text{k}\Omega$  should be adequate. See Fig. 2. The drain on the battery is negligible, since at most the current is equal to meter full-scale current. In the absence of input the current will be just the leakage current of a silicon planar transistor, which may be ignored. Hence there is not even need for an on-off switch, as the battery should last its shelf-life.

# BINARY NIM

by G. A. FRENCH



**N**IM IS ONE OF THE OLDEST mathematical games for two persons that has been devised by man. Despite its apparent simplicity the game allows considerable scope for ingenuity, and a wide range of moves is possible.

To play the game a number of counters, or coins, are laid out in horizontal rows. There can be any number of rows and any number of counters in each row, but the most common version of Nim has three rows with three counters in the top row, four in the middle row and five in the bottom row. The layout is shown in Fig. 1. Each player, in turn, takes one or more counters from a single row, the winner being the person who picks up the last counter (or counters). The trick here is to endeavour to take counters such that there are always one or more counters in two of the rows. Since the opponent is only allowed to take counters from one row he may then be manoeuvred into leaving the final counter on its own.

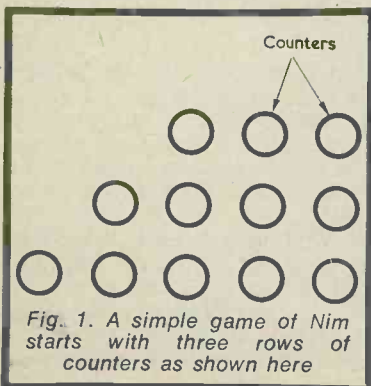

Fig. 1. A simple game of Nim starts with three rows of counters as shown here

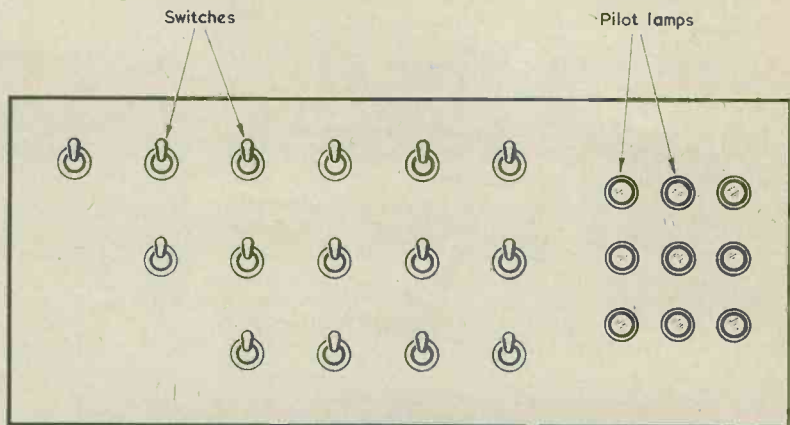

Fig. 2. A suitable front panel layout for the electrical version of Nim. This can be fitted to a shallow case holding the requisite battery or heater transformer

## ELECTRICAL VERSION

In the electrical version of the game to be described here the counters are replaced by three rows of toggle switches, an arbitrarily-chosen quantity of six, five and four switches per row being incorporated. Instead of taking away counters the switches are put up, the only proviso being that they are put up in order, starting from the left hand side. Mounted alongside the switches are three rows of small pilot lamps. A suitable layout is shown in Fig. 2.

The operator of the game challenges an opponent and the game starts. To begin with, all switches are set to the down position, whereupon a number of the lamps become illuminated. As switches are

turned off different lamps light up in a manner which has no obvious significance to the opponent, and he becomes increasingly more mystified when he finds that the challenger always studies the light pattern before he makes his next move. The challenger will win in almost every instance, losing only if the opponent happens to be exceptionally lucky, is an extremely good player of the game or fathoms the secret of the lamp illumination pattern.

## UNBEATABLE STRATEGY

To understand why the challenger is able to play so skilfully we must digress a little to discuss a little-known fact about Nim. This consists of an unbeatable strategy for the



game which was discovered, around 1900, by Charles Leonard Bouton, an associate professor of mathematics at Harvard University. (The author is indebted for his information to Martin Gardner, who refers to it in his book *Mathematical Puzzles and Diversions*, published by Pelican Books.)

Bouton stated that any combination of counters in Nim represents either a 'safe' or 'unsafe' position. A 'safe' position is one which must always force the opponent to move to an 'unsafe' position, regardless of his skill at the game. An 'unsafe' position can be changed in one move to either a 'safe' position or another 'unsafe' position. On the other hand any move from a 'safe' position inevitably leads to an 'unsafe' position. The person employing the strategy ensures that he takes up a 'safe' position as soon as possible in the game. Ideally, this should be at his first move but he may have to wait for several moves if the opponent has, himself, unknowingly taken up one or more 'safe' positions.

To determine whether a position is 'safe' the number of counters in each row is initially written out in binary form, the binary numbers being positioned above each other so that the individual figures may be added in columns. If the total in each column is zero or an even number the position is 'safe'. If one or more columns adds up to an odd number the position is 'unsafe'. A typical example of the calculation is shown in Fig. 3(a), where it is assumed that a three-row game has proceeded to the state where the top row has two counters (binary 10) the centre row has four counters (binary 100) and the bottom row has five counters (binary 101). This position is 'unsafe' because two of the columns add up to an odd number, but it may be changed to 'safe' by taking one counter from the top row, which then becomes binary 1 as in Fig. 3(b). Now, all

10	1
100	100
101	101
211	202
(a)	(b)

Fig. 3. If the number of counters in each row of a game of Nim is written out in binary notation, the sum of each column of figures indicates whether the position is 'safe' or 'unsafe'. The situation in (a) is 'unsafe' and that in (b) is 'safe'.

the columns add up to zero or an even number. Any move following the situation in Fig. 3(b) must result in an 'unsafe' position, as the reader will discover if he checks for himself. Indeed, it is an amusing pursuit to continue the game in its binary form to the inevitable conclusion, taking the position repeatedly from 'safe' to 'unsafe' and back to 'safe' again, and using random changes to create the 'unsafe' situations.

### BINARY LAMP PATTERN

We may now return to the Nim-playing device shown in Fig. 2. As will probably by now have been guessed, the lamps in this diagram represent the binary equivalent of the number of switches that have not been put up. Binary 1 is indicated when a bulb is lit and binary zero when a bulb is extinguished, and the three bulbs in each row are read, from left to right, as though they were figures in a table. To adopt the Bouton strategy, moves are made which cause the total number of lit bulbs in each of the three vertical columns to equal 2 or zero.

Fig. 4 illustrates the switching circuit, and we shall commence by examining the top row of switches. When the game is played, all the switches in the top row are initially turned down, and are put up from left to right, starting with S6 and ending with S1; but it will be easier, for explanation of the circuit, to assume that they are all up and are then put down starting from the S1 end.

When S1 is put down, a circuit is completed from the battery positive terminal via S4, S2 and S1 to pilot lamp PL1, which then glows (giving binary 1). We next put S2 down, whereupon it breaks the circuit to S1 and completes it to PL2. PL2 lights up and PL1 extinguishes (binary 10). When S3 is put down a further circuit is completed via S4, the upper contacts of S5 and via S3, to PL1, with the result that both PL2 and PL1 are lit up (binary 11).

S4 is next put down, whereupon it breaks the circuit to S3 and S2 and completes a circuit to PL3. PL3 is now illuminated and PL1 and PL2 extinguish (binary 100). Putting down S5 completes a circuit to PL1 which, in company with PL3, is now lit up (binary 101). The function of the upper set of contacts in S5 is to break the connection between S3 and S2 when S5 is put down; otherwise PL2 would also light up. Finally, putting S6 down breaks the circuit to S5, whereupon PL1 extinguishes, and completes a circuit to PL2. Thus, PL3 and PL2 are now lit up (binary 110).

# AUDIO AMPLIFIERS



15 Transistor & Valve Designs for the Home Constructor

Amplifiers for Tuner Units, Record Players, Tape Recorders, Public Address, etc., etc.

Includes contributions by such well-known authors as

A. S. Carpenter, A. Kinloch, E. Govier, G. A. French, F. G. Rayer, P. F. Bretherick, K. Jones, D. Aldous, R. Murray-Shelley, C. Swires, G. A. Stevens and V. E. Holley.

Edited by J. R. Davies

124 pages

**PRICE 53p**

Postage 6p

To: DATA PUBLICATIONS Ltd., 57 Malda Vale London W9

Please supply ..... copy(ies) of "Audio Amplifiers", Data Book No. 18. I enclose cheque/crossed postal order for.....

Name.....

Address.....

.....

.....

.....RC

BLOCK LETTERS PLEASE

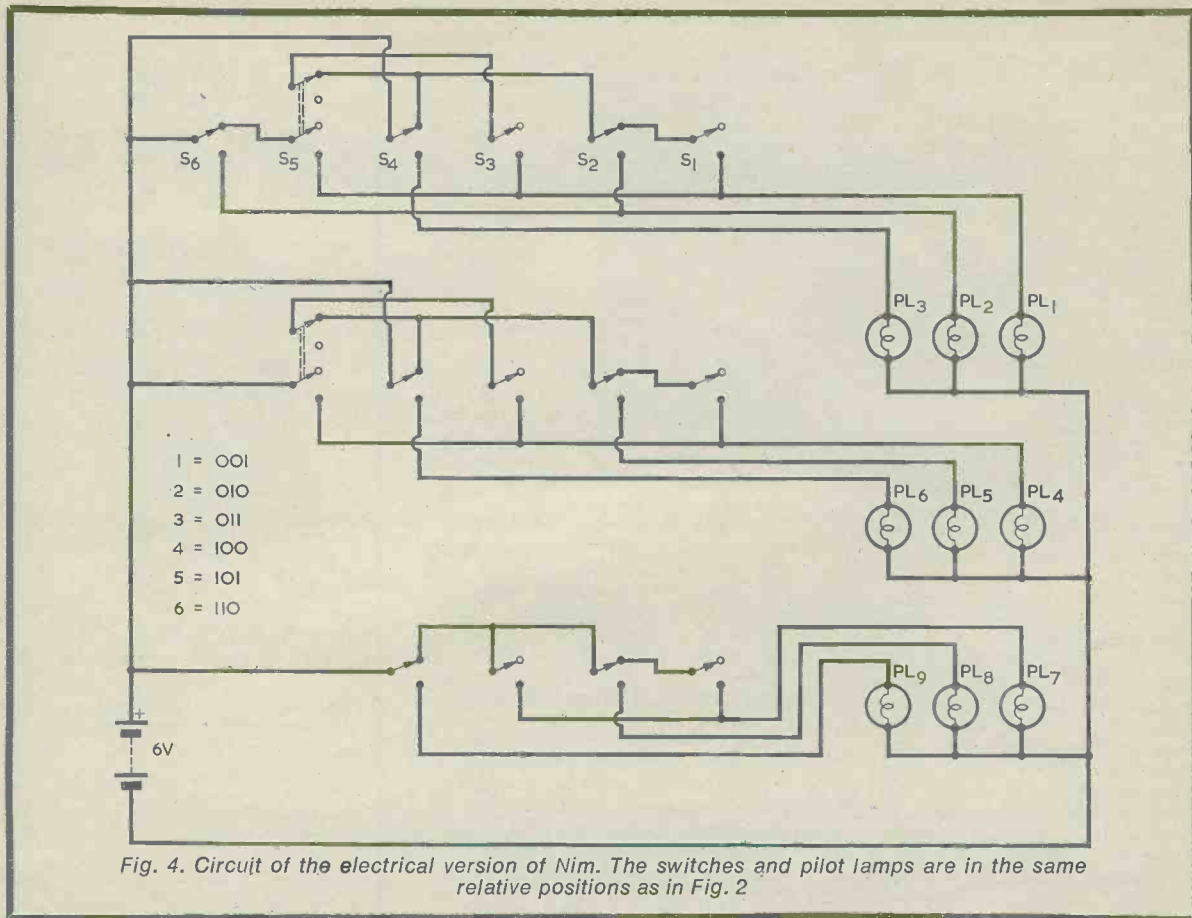

Fig. 4. Circuit of the electrical version of Nim. The switches and pilot lamps are in the same relative positions as in Fig. 2

As already mentioned, when the game is played all the switches are initially down, whereupon the pilot lamps indicate binary 110. The binary number reduces accordingly as switches are put up.

The middle and bottom row of switches in Fig. 4 use the same circuitry as the top row but extend only to decimal 5 in the middle and to decimal 4 at the bottom. When all the centre switches are down, the centre row of bulbs indicates binary 101, and when all the bottom switches are down the bottom row of bulbs indicates binary 100.

In the interests of battery economy the lamps may be low-consumption 6 volt panel or dial lights. These will require less power than bulbs of the flash-light variety. If desired, the circuit could be powered by a 6.3 volt heater transformer instead of by a battery. The transformer is to be preferred if the Nim-playing device is to be run for long periods since the current drain given even by low-consumption pilot lights can still be relatively high.

Fifteen toggle switches are required, two being d.p.d.t., seven being s.p.d.t. and six being s.p.s.t.

For the sake of appearance at the front of the panel on which they are mounted they should all have the same type of dolly, bush and mounting nut.

### GAME APPROACH

Before concluding, it will be of advantage to consider an actual game of Nim played with the aid of the pilot lamps. It is assumed that the operator has memorised the binary equivalents of decimal 1 to 6.

At the start of the game the lamps will indicate three rows of binary numbers, as shown in Fig. 5(a). This is obviously an 'unsafe' combination but it may be made 'safe' by putting up five switches in the top row, giving the result shown in Fig. 5(b), or by putting up one switch in the bottom row, giving the result shown in Fig. 5(c). If the challenger (i.e. the person who knows the secret of the lights) is first to start he can make either of these moves, whereupon the opponent is forced to move to an 'unsafe' position which the challenger can then change to 'safe' again. Under these conditions the opponent

has no chance of winning whatsoever. However, the challenger might be wise to avoid using these two opening moves too frequently as they will become recognised and used by the opponent. He may,

110	1	110
101	101	101
100	100	11
<u>311</u>	<u>202</u>	<u>222</u>
(a)	(b)	(c)
100	10	10
101	101	1
11	11	11
<u>212</u>	<u>122</u>	<u>22</u>
(d)	(e)	(f)

Fig. 5. Illustrating the initial state and subsequent moves in a game of electrical Nim. The individual positions are discussed in the text



therefore, start by making a random move to another 'unsafe' position, taking the precaution to ensure that this does not leave the same number of switches down in any two rows. (If he did, an experienced player of the game would follow a well-established Nim tactic and would put up all the switches in the third row. This, incidentally, is an obvious application of the Bouton strategy.) The challenger then waits until the opponent takes up an 'unsafe' position, after which

he changes this to a 'safe' situation and is then in command of the game.

Let us next assume that it is the opponent who is first to start and that, by luck, he puts up one switch in the bottom row, giving the 'safe' result of Fig. 5(c). The challenger can now only make a random move. Let us say he puts up two switches in the top row, resulting in the 'unsafe' result of Fig. 5(d). The opponent next puts up two further switches in the top row,

whereupon the 'unsafe' position of Fig. 5(e) appears. The challenger then puts up four switches in the middle row, and the 'safe' result of Fig. 5(f) is given. The opponent is now trapped; every move he makes must be to an 'unsafe' position which the challenger promptly changes to a 'safe' position. There can only be one conclusion to the game and that consists of defeat for the opponent and victory for the challenger. ■

# The RADIO CONSTRUCTOR

## SEPTEMBER ISSUE

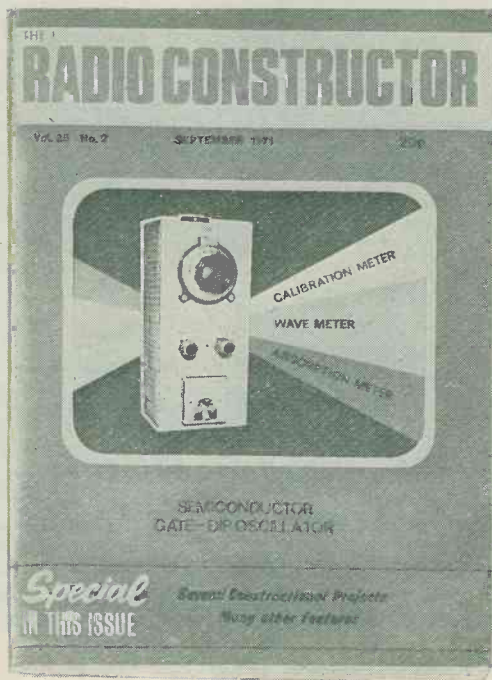

Look out for this cover  
on your bookstall

ON SALE  
1st SEPTEMBER  
20p

Copies may also be obtained direct from the Publishers. 24p including postage. Published by: Data Publications Ltd. 57 Maida Vale, London, W.9

AUGUST 1971

Another GREAT number  
Constructional articles include

Semi-conductor Gate-dip  
Oscillator  
(Cover feature)

●  
Brake Light Failure Indicator

●  
Automatic Morse Practice Keyer

●  
High Impedance Transistor  
Pre-amplifier

●  
**PLUS**

- ★ MORE CONSTRUCTIONAL PROJECTS
- ★ NEWS COVERAGE
- ★ SHORT WAVE SCENE
- ★ SUPPORTING FEATURES
- ★ DATA SHEET 54

# THE TRANSIMATCH

by  
H. T. KITCHEN

A useful approach to the problem of matching transistors

THERE ARE APPLICATIONS WHICH REQUIRE THAT transistors, normally in pairs, must be closely matched for hFE at a given supply voltage and collector current.

For obtaining closely matched pairs, or even sets of transistors, recourse has to be made to a transistor tester or analyser. As far as amateurs are concerned it is probably safe to state that most do not possess such instruments. Indeed, even quite large retail establishments seem to manage quite well without them!

The circuit to be described was designed to enable transistors to be rapidly sorted into matched pairs or sets within quite close limits under small signal conditions. Once its method of operation has been grasped, the circuit is capable of being simply modified to enable power transistors to be matched, again to quite close limits. The accuracy attainable under any operating conditions is dependent upon the quality of some of the components used, and upon the skill of the operator.

## BASIC CIRCUIT

The circuit, shown in Fig. 1, will be seen to be very simple. The transistors shown within broken lines are the ones to be tested and are, therefore, not an integral part of the circuit. They are shown as n.p.n. types, though it will be obvious that p.n.p. types can also be matched, all that is required being the reversal of the supply voltage, Vcc.

In order to explain how the circuit functions a slight digression, to Fig. 2, is required. This illustrates the Wheatstone bridge, composed of four resistors R1, R2, R3 and R4, and having a centre-zero meter connected to the junctions of R1, R2 and R3, R4. A supply voltage is connected to the junctions of R1, R3 and R2, R4. If R1 = R3 and R2 = R4, the voltages at the junctions of R1,R2 and R3,R4 will be equal and the current through the meter will be zero, giving the well known equation for balance of

$$\frac{R1}{R2} = \frac{R3}{R4}$$

If one or more resistors are changed in value, and providing the changes do not balance out, the voltage levels at the junctions of R1,R2 and R3,R4 will be dissimilar and a current will flow through the meter, the direction and magnitude of this current depending upon the direction and extent of resistance change.

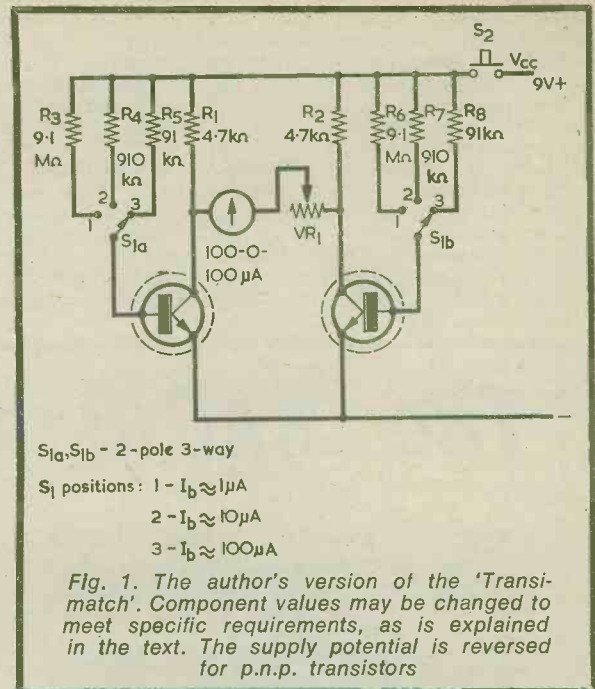

Fig. 1. The author's version of the 'Transimatch'. Component values may be changed to meet specific requirements, as is explained in the text. The supply potential is reversed for p.n.p. transistors

## COMPONENT VALUES

Since the hFE of a transistor is dependent upon collector current, and since hFE may have to be a certain value for any given application, it is clearly necessary to provide a means of varying the collector

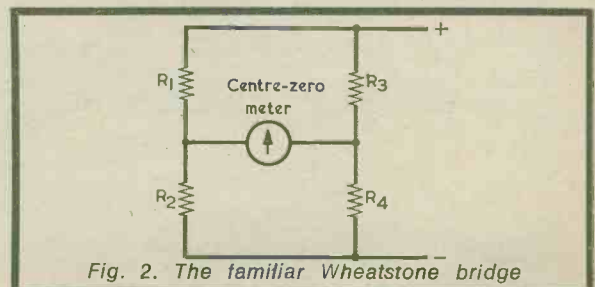

Fig. 2. The familiar Wheatstone bridge



current. In Fig. 1 this function is performed by S1(a)(b) and R3 to R8. Assuming a 9 volt supply, resistance values of 9.1M $\Omega$ , 910k $\Omega$  and 91k $\Omega$  will allow nominal base currents of approximately 1 $\mu$ A, 10 $\mu$ A and 100 $\mu$ A to flow in each transistor. Since the hFE of small signal transistors can extend from a minimum of 30 or so to a maximum value of 900, these base currents can cause a collector current to flow between the limits of 30 $\mu$ A and (theoretically anyway) 90mA, a range of 3,000:1.

Such a very wide range of collector currents poses problems when we try to allot values to the two collector loads R1 and R2. Clearly, a low value for these resistors will mean that Vce will equal Vcc at low collector currents, whilst a higher value will result in the collectors bottoming at medium or high collector currents, or being unable to pass the appropriate collector currents due to the limiting effects of R1 and R2.

We must, therefore, try to determine what an 'average' Ic will be for medium gain transistors. For the writer's own requirements a medium hFE was determined at 100, and an average Ic at 1mA. Vcc was set at 9 volts, and R1 and R2 were made 4.7k $\Omega$ . Using the 10 $\mu$ A base current position of S1(a)(b), a transistor with an hFE of 100 will cause an Ic of 1mA to flow. Therefore, a potential difference of 4.7 volts will be set up across R1 and R2 resulting in a Vce of 4.3 volts. Other values of Ib, hFE and Ic will result in different Vce's, and

initially set so that it is at maximum resistance (i.e. meter sensitivity is at a minimum) for each transistor being checked. One transistor is picked as a 'standard' and inserted into one of the holders. S1(a)(b) is set to a position corresponding to the approximate hFE to be expected. An 'unknown' is inserted into one of the holders. S2 is pressed, and VR1 adjusted as required to provide a reasonable meter deflection. If the pair are not in balance, the 'unknown' is removed, S2 released and VR1 returned to insert maximum resistance again. Another 'unknown' is then tried, and the process repeated until a pair are found to balance. If this does not occur, another transistor is selected as a 'standard' and the process repeated until a pair are eventually found to balance. As with all test instruments, familiarity will eventually produce a 'feel' for the device, such that though transistors may not balance exactly they can still be matched quite closely.

In the normal course of events, transistors of only one family, i.e. BC109's, 2N3707's, etc., will be matched in pairs. However, in a recent 'panic stations' situation, a BC109 was successfully paired with a 2N2926, the pair working very well in the final circuit in which they were used. However, and particularly where germanium transistors are concerned, close matching of hFE's may still fail to produce a successful working pair, for other important factors such as leakage current may obtrude to the detriment of final circuit operation. Nevertheless, for its primary function the 'Transimatch' circuit is a most useful one.

## CONSTRUCTION

The basic circuit can be, as was the original circuit, built up on S-DeC board.\* This represents what is probably the easiest approach for occasional use, as the circuit can be set up quickly, components can be changed, and the whole lot dismantled once matching has been effected. If much use is envisaged, then a more permanent version is desirable. Again, the individual constructor must decide for himself, after reviewing his own requirements.

## COMPONENTS

Constructors wishing to obtain the same base current values as were chosen by the writer may find difficulty in obtaining the 9.1M $\Omega$ , 910k $\Omega$  and 91k $\Omega$  resistors employed for R3 to R8. The values can alternatively be made up by 6.8M $\Omega$  and 2.2M $\Omega$  in series for R3 and R6, 680k $\Omega$  and 220k $\Omega$  in series for R4 and R7, and 68k $\Omega$  and 22k $\Omega$  in series for R5 and R8. These values will allow approximately the same base currents to flow. Ideally, the resistors employed for R3 to R8 should have a tolerance on value of 1%.

The collector load resistors, R1 and R2, should also have a tolerance of 1%.

If it is intended to modify the circuit for the matching of power transistors, the values of R1 and R2 will need to be considerably lower than those used by the writer, as also will the values of the base resistors. The values required may be calculated following the same reasoning as was used by the

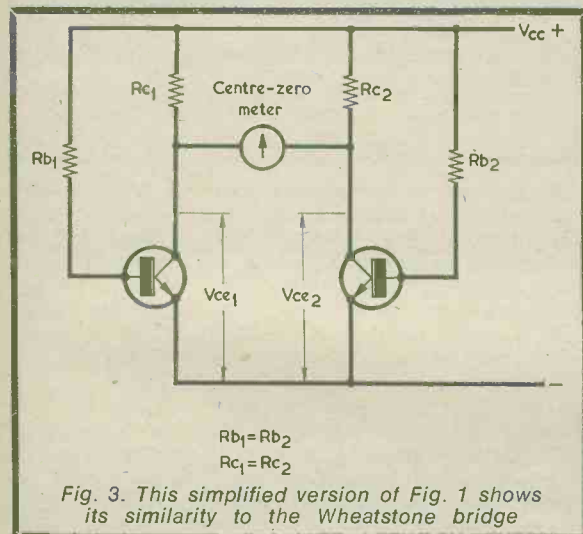

Fig. 3. This simplified version of Fig. 1 shows its similarity to the Wheatstone bridge

therefore the individual constructor must select his own values for R1 and R2 to suit his own requirements. With the values used by the writer the null indicating meter should be a 100.0-100 $\mu$ A type, and VR1 should be a 100k $\Omega$  linear track component.

The method employed for making connections to the two transistors also depends upon individual requirements. The writer found that the most convenient scheme consisted of fitting two transistor holders, into which the lead-outs of the transistors to be checked could be inserted.

## USING THE 'TRANSIMATCH'

To use the instrument, a batch of transistors of similar type is necessary. VR1 must always be

\* S-DeC Boards are available from G.W. Smith and Co. (Radio) Ltd., 3 Lisle St., London, W.C.2.

author in choosing the resistor values for his own version. The supply must also be capable of providing the extra current required. Under these condi-

tions a less sensitive meter can be used, and a 1.0-1mA meter would be adequate. The value of VR1 may then be reduced to 10kΩ.

# ALTERNATIVE MULTI-VOLTAGE CIRCUIT

by  
**B. E. HAWKER**

A recent article described a means of obtaining 12 different output voltages from the Douglas Type MT3 mains transformer. Voltage selection was by way of a 12-way rotary switch, which had the disadvantage of causing output current to be limited to 300mA. The present article describes an approach enabling output currents up to 2 amps to be drawn

THE WELL-KNOWN DOUGLAS MAINS TRANSFORMER Type MT3 (listed in some catalogues as MT3AT) offers a wide range of secondary voltages, all at a current rating of 2 amps. Fig. 1 shows the voltages present at the secondary taps of this transformer and it will be seen that, by choice of the requisite taps, it is possible to obtain any of the following 13 secondary voltages: 3V, 4V, 5V, 6V, 8V, 9V, 10V, 12V, 15V, 18V, 20V, 24V and 30V. The letters A to F, also appearing in Fig. 1, are not applicable to the transformer, but are used for the switching design procedure to be described in this article.

In an article in the September 1970 issue\* it was shown that 12 of the 13 available voltages could be selected by a 2-pole 12-way switch, the voltage not catered for being 9 volts. Unfortunately, the use of a rotary switch restricted output current to 300mA only.

\* W. Philips, "Multi-Voltage Switching Circuit", *The Radio Constructor*, September, 1970.



Fig. 1. The secondary voltages offered by the Douglas mains transformer Type MT3

## ALTERNATIVE CIRCUIT

The approach now to be described dispenses with the rotary switch and employs changeover switches, which can be readily obtained with a 2 amp rating. It first becomes necessary to find the simplest switching circuit that may be employed and, for this, we can resort to a mathematical treatment as would be employed with AND/OR logic.

The previous author's selection of 12 voltages from a possible 13 may be chosen in four ways, since the 12V output can be taken from AB or BE and the 15V output from AC or CF.

The four expressions which result are shown in Fig. 2, in which the letters correspond to those in Fig. 1.

- ① AB + AC + AD + AE + AF + BC + BD + BF + CD + DE + DF + EF
- ② BE + AC + AD + AE + AF + BC + BD + BF + CD + DE + DF + EF
- ③ AB + CF + AD + AE + AF + BC + BD + BF + CD + DE + DF + EF
- ④ BE + CF + AD + AE + AF + BC + BD + BF + CD + DE + DF + EF

Fig. 2. Expressions derived from the secondary voltages available if the 9 volt output is omitted

Inspection shows that none of the expressions is symmetrical, so factorisation will lead to only partial simplification; but if the 4V output is omitted and 9V chosen in its place (which the author considers more useful anyway), and if the 12V and 15V tapings are chosen as in expression 2, then the expression becomes symmetrical, i.e. A, B, C, D, E, and F each appear four times. The expression can be factorised to good effect, as is shown in Fig. 3.

The final expression can be translated into the switching circuit of Fig. 4, in which five changeover switches are employed. Five such switches, rated at 2 amps, can be obtained for less than the cost of the rotary switch they replace, the full current rating of the transformer can be used and the wiring is greatly simplified.

On the debit side, obviously, one has to make a Table of switch positions for various output voltages but this can be kept simple and made small enough to fit on the front panel of any equipment incorporating the transformer.

If the switches are physically up when in the positions shown in Fig. 4, then all that is necessary

$$AC + AD + AE + AF + BC + BD + BE + BF + CD + CE + DF + EF = (A+B)(C+F) + (A+BXD+E) + (C+FXD+E) \dots \textcircled{5}$$

Fig. 3. When the 4 volt output is omitted instead, the expression becomes symmetrical and can be readily factorised



# PROJECT MOONRAY

## - Gets under way

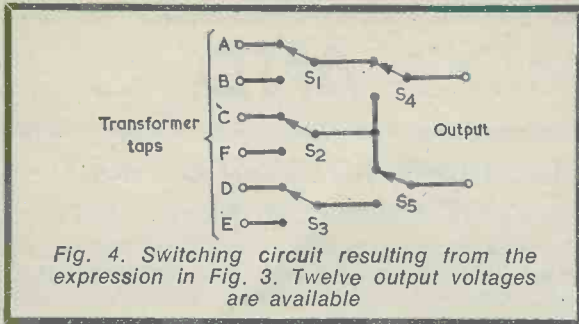
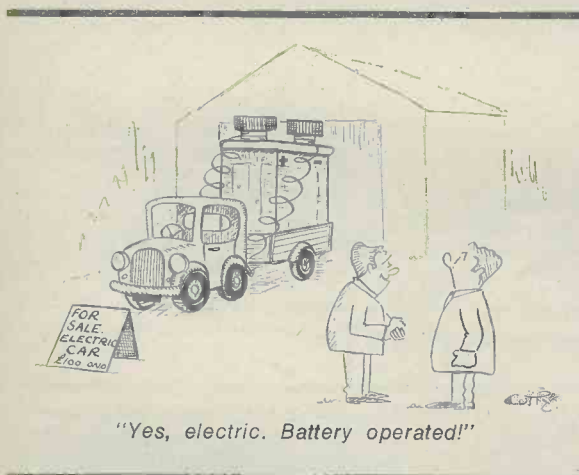

Fig. 4. Switching circuit resulting from the expression in Fig. 3. Twelve output voltages are available

is to tabulate which are to be pressed down for a required voltage. A suitable Table accompanies this article. In this, there is no entry in the right-hand column for the 15V output; this is because the 15V output is given with all switches up.

TABLE

Output Voltage	Switches Down
0	4
3	1
5	4, 5
6	2, 3, 4, 5
8	1, 5
9	3, 4, 5
10	2, 4, 5
12	1, 3, 5
15	—
18	1, 2
20	5
24	3, 5
30	2



IN 1960, N. K. MARSHALL, W6LO/2, PROPOSED THAT AN amateur radio UHF repeater station should be placed on the moon, by an astronaut, at some convenient future date. In 1967, an organisation called NASTAR (Nassau College Amateur Satellite Tracking, Astronomy and Radio) undertook the sponsorship of this idea, which has come to be called Project Moonray.

Writing in AMSAT Newsletter, Marshall outlines the progress the project has made to date. Thanks to the help of a group of highly qualified technical advisors, who are all radio amateurs, the design data has been completed and an operational prototype is under test and the construction of a flight model is soon to be started. NASTAR hopes to get NASA to put the MOONRAY repeater station on to the moon via one of the remaining Apollo missions. It is hoped to provide a repeater having a life of a year or longer, which will give free-access UHF repeater facilities for world wide line of sight amateur communication in the 432 MHz band.

MOONRAY I will contain a highly sensitive low-noise receiver, a signal processor, an identifier, six to eight channels of telemetry and a laser receiver with optics. Power will be supplied by an isotope fuelled thermoelectric generator having a half-life of 87 years. The up-link frequency will be 439.9 MHz and the down-link 430.1 MHz. All modes of transmission will be usable.

In appearance, the unit will take the form of a louvered Metal Cylinder about six inches in diameter and ten inches long, with three retractable legs for support and a special aiming mechanism to aid accurate line of sight to earth orientation of the Antenna. The importance of this part of the mechanism will be well understood by those readers who read our feature "Apollo Communications" in our June 1971 issue, in which it was pointed out that the earth subtends an arc of only two degrees or so from the moon.

Amateur ground stations should have antennas with at least 15 db gain, capable of tracking the moon; stable, low-noise crystal controlled converters feeding into good communication receivers. Transmitter power estimated adequate for CW about 50 watts, progressing through say 100 watts for FSK, up to 1,000 watts for slow-scan TV.

## SWITZERLAND CALLING

SBC's Summer '71 broadcast schedule will include another language for listeners overseas. For the first time a programme in Romansh, Switzerland's fourth national language, will join the transmissions in English, German, French, Italian, Spanish, Portuguese, Arabic and Esperanto. In providing a link between Switzerland and Romansh-speaking Swiss abroad, SBC hopes to contribute to the strengthening of a language spoken by only one per cent of the population of Switzerland.

Among the changes for Summer '71 in SBC's English programme will be a roundtable entitled "To Be Quite Frank", a feature on different aspects of life in Switzerland. It will be broadcast every first Sunday.

## THE "MINI-BOARD"

Having been a pioneer of the multi-socket power board business for more than ten years, Lexor Dis-boards Ltd., are aware that 75% of users' needs can be met by only one model. This has now been specially designed and set up for quantity production. It is slimmer, lighter, safer and more elegant than any previous "Dis-board" and sells for only £3.95.



Four high-grade 13A ivory sockets are mounted in a slim blue leather-finish case and fed via 5 ft. of cable from a ready-fitted 13A ivory fused plug. There is the characteristic red safety warning lamp, and the units can be used portable and free-standing or easily fixed permanently to walls, benches, etc. Simple cable extensions of 15 ft. or 25 ft. are available for the situations where the flex will not reach.

Illustrated brochures carrying full details, prices and sales terms are available from Lexor Dis-boards Limited, 25/31, Allesley Old Road, Coventry. Telephone Coventry 72614/72207.

## TV TAPE RECORDER AUTOMATIC FAULT WARNING

BBC engineers have developed a system that gives operators of television tape recorders automatic warning if a fault develops. Compared with the normal technique, this is a valuable saving in cost and time.

In the usual TV tape recorder there are four separate sections which record horizontal strips of the picture. If one of these stops recording properly, which is not an uncommon fault, then every fourth strip of the picture is lost. The result is a set of dark lines across the screen, rather like looking through a venetian blind. As an insurance against this kind of breakdown, it is usual to have two recorders working simultaneously.

But a snag about recorders of this type is that you cannot replay a tape as you are making it. Like some domestic sound recorders, the same parts are used for both recording and playing. So you have to wait until a recording is finished, wind the tape back, and then sit through the whole thing again, just to see if it was recorded properly.

The BBC engineers have devised a very simple method of checking electronically that each of the four sections of the machine are recording properly. The extra equipment checks the recording by observing that each section of the recorder has laid down its strip of picture on the tape, producing a regular pattern. If one section fails then the monitoring device lights a warning lamp, the recording can be stopped, and the machine replaced or cleared very quickly. This way only one expensive video recorder is needed, and the time of high-paid production staff is saved too.

## Quotes

"Each year the concept of the world as an electronic village moves perceptibly closer to reality."

— Peter McCann — director of Cable & Wireless Ltd.

"Have you noticed that commercial television advertisements for sweets and cereals and jellies treat children in much the same way as ads. for dogfood treat dogs — animated and appealing possessions, to be kept happy and in good condition?"

— Alisdair Fairley in *The Listener*

## Talking Point

Most of us have had some very amusement over the way some family cars are chosen, it being taken on trust that there is an engine under the bonnet.

For radio amateurs who have gone mobile there is a very real consideration, other than a purely motoring one, to be taken into account when buying a car.

An article in *Mobile News*, the journal of the Amateur Radio Mobile Society, specifically deals with vehicle interference produced by a particular car, and advises against purchasing the model unless one is prepared to work very hard to obtain interference free reception.

## ITT INTRODUCE DIGITAL CLOCK WITH LARGE NUMERALS

Complementary to the established miniature digital clock with electric alarm and 'going-to-sleep' time switch, ITT has now introduced a bigger version with 12 mm high numerals.

The new digital clock can be used in larger radios or simply as a desk or mantleshelf time piece. This because two versions are available — single mains powered digital clock with switching or same clock with 24 hour alarm facility, variable time 'going-to-sleep' switch and illumination.

Figure wheels of the new clock are 55 mm diameter. Power required is 220-240V, 50Hz. Ambient operating temperature can be from -10°C to +50°C.



THE RADIO CONSTRUCTOR



# COMMENT

## EMI HOLDS 'OPEN DAY' AT APPRENTICE TRAINING SCHOOL

EMI's training facilities were open to inspection by parents, and representatives from local schools and authorities, when the Group's Apprentice Training School held its annual Open Day at Hayes, Middlesex.

This event enabled the parents of 60 first-year apprentices to meet instructors and to inspect the facilities used in training their sons.

The Open Day also provided an opportunity for representatives from schools, technical colleges and local authorities within the West London and surrounding areas to assess the different EMI training schemes and to talk to some of the young men undergoing various types of training.

The EMI Apprentice Training School has an average annual intake of 60 apprentices mainly in the 16 and 17 year age bracket. Irrespective of their category, whether technician or craftsman, all these complete a standard course in the fundamental principles of workshop technology and the basic theories behind electronic and mechanical techniques. This one-year basic course provides a good general background for the sort of work that the apprentice will eventually specialise in. The syllabus covers a number of subjects, and periods are spent at a workshop bench or machine tool, in the technical drawing office and in elementary and advanced electronic training laboratories.

The department has a staff of 12 full-time instructors and training officers and has a total of around 350 apprentices on its strength at any one time.

On successful completion of an apprenticeship, a young man or woman can enter a whole range of careers within the 14 electronics-based companies and divisions which comprise EMI's Electronics & Industrial Operations.

## GLASGOW R.A.E. COURSE

There will be a Radio Amateurs' Examination Course at the Glasgow College of Nautical Studies, 21, Thistle Street, Glasgow, C.5., commencing Tuesday, 14th September 1971.

The Course will meet at the College on Tuesdays and Thursdays from 7 p.m. to 9.30 p.m. Enrolment will take place at the College at 7 p.m. on the opening evening, and the fee for the course is £3.00, payable on enrolment. Students under the age of 18 on 1st August, 1971, will not be required to pay a fee.

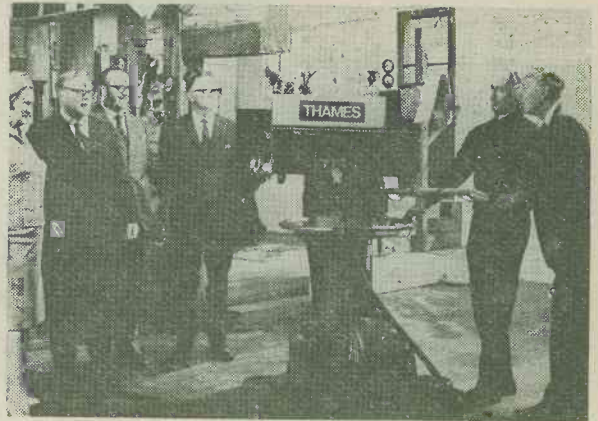

A behind-the-scenes look at a major British television studio was one of the highlights of a recent visit to Britain by the chairman of the South African Broadcasting Corporation, Dr. P. J. Meyer. Accompanied by his wife and Mr. J. N. Swanepoel, SABC's director in chief, management, Dr. Meyer visited Thames Television's main studio production centre at Teddington, Middlesex.

The photograph shows (l to r) Mrs Meyer, Dr. P. J. Meyer, Mr. J. N. Swanepoel, and Mr. N. Filmer (EMI South Africa) on one of the studio sets while Sir Joseph Lockwood (r) assesses the picture quality of an EMI type 2001 colour camera.

## MOBILE RALLY

The Fourteenth Annual Derby Mobile Radio Rally will be held on Sunday August 15th 1971, at Rykneld School's, Bedford St., Derby. The attractions include Band Concert, Junk Sale, Prize Draw, Children's Events, Trade Stands, Competitions, Demonstrations, Ice Cream, Refreshments, Etc.

G3ERD/A on 160 metres. G8DBY on 4 and 2 metres.

Admission and parking are free.

Further details from Tom Darn G3FGY, Hon. Organiser, "Sandham Lodge", 1, Sandham Lane, Ripley, Derbys. DE5 3HE. Telephone Ripley 2972.

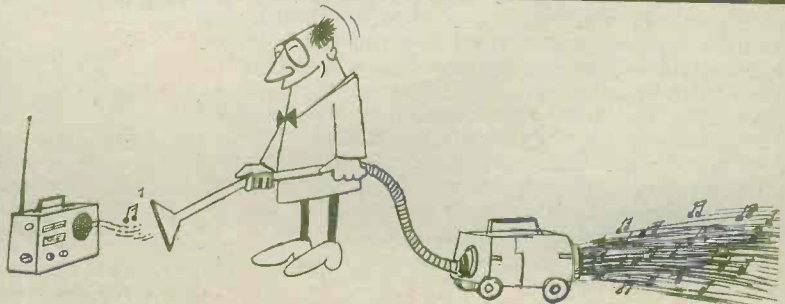

CORK

# AERIAL DISTRIBUTION BOARD

by

C. S. JOHNSON

A simple and effective aerial distribution system having especial appeal for the constructor who is proficient at metalwork

THE IDEA TO BE DESCRIBED IS ONE WHICH THE WRITER has seen employed in ships' radio rooms, and it enables any number of aerials to be routed to any number of receivers. A particular advantage is that more than one aerial can be connected to more than one receiver or that more than one receiver can be connected to any aerial or combination of aerials. The distribution board will be of particular interest to the short-wave enthusiast who has a number of receivers and aerials available.

## BASIC PRINCIPLE

The basic principle is illustrated in Fig. 1(a), in which it is assumed that there are four aerials and three receivers.

In Fig. 1(a) four flat brass strips are positioned vertically, each of these connecting to a single aerial. Below them, and separated by a sheet of insulating material (not shown for purposes of clarity) are three flat brass strips which are positioned horizontally. These connect to the receivers.

Holes are drilled in the vertical strips at each point of intersection, as illustrated. Let us say for purposes of example, that these holes are 2BA clear. Immediately below each of these holes a second hole is drilled in the horizontal strips. This second hole is tapped 2BA.

As accessories, a number of short-circuiting studs are available, these having the general construction illustrated in Fig. 1(b). To connect a particular aerial to a particular receiver, one of these short-circuiting studs is inserted and screwed down at the point of intersection of the appropriate strips, whereupon the two strips become reliably connected together, as shown in Fig 1(c). This connection will be low-resistance and will not give rise to crackles.

It will be seen that, provided a reasonable number of short-circuiting studs are available, any aerial or combination of aerials can be connected to any receiver or combination of receivers.

## CONSTRUCTION

A suitable construction is shown in Fig. 2, where the whole assembly is mounted in an earthed metal

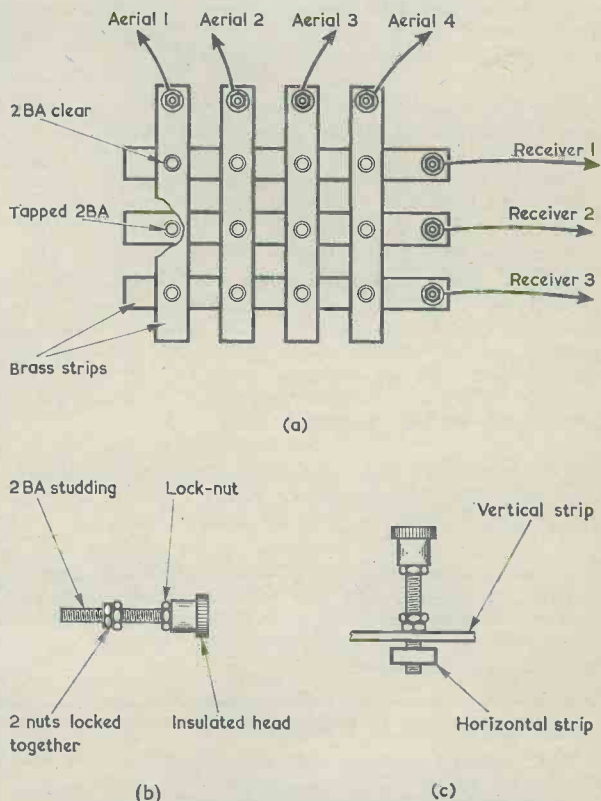

Fig. 1(a). The basic distribution board principle. The vertical and horizontal strips are separated by a sheet of insulating material, which is omitted here for clarity. The number of strips and the size of the holes at intersections can be varied to suit individual requirements. It is assumed here that the holes are 2BA clear and 2BA tapped  
(b). A short-circuiting stud  
(c). The short-circuiting stud screwed in to connect a vertical strip to a horizontal strip



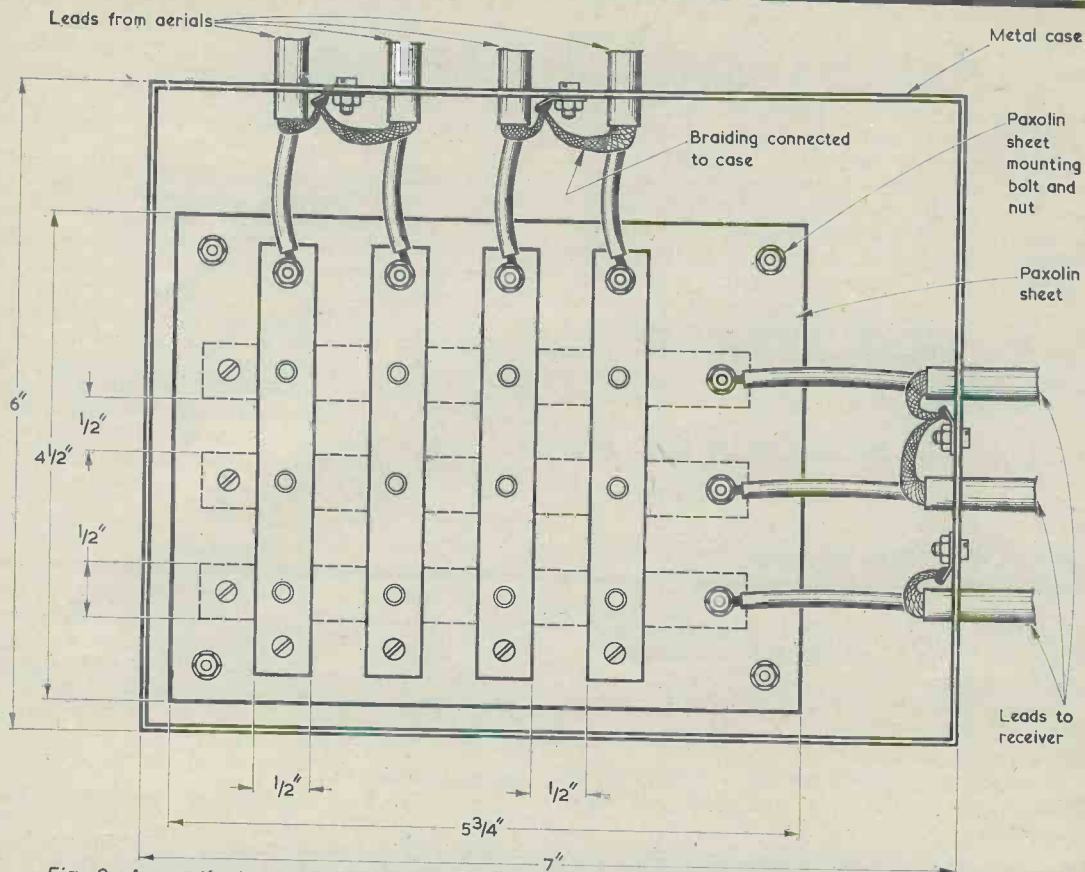

Fig. 2. A practical distribution board assembly with suggested dimensions, which may be varied if different numbers of strips are employed. Four spacing washers under the Paxolin panel at each mounting screw space the panel away from the bottom of the metal case

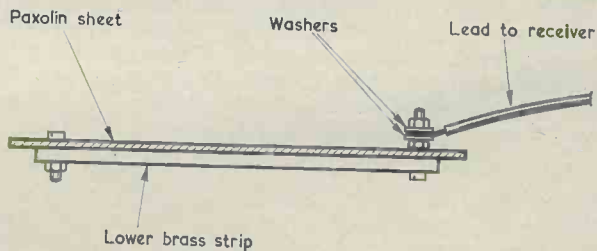
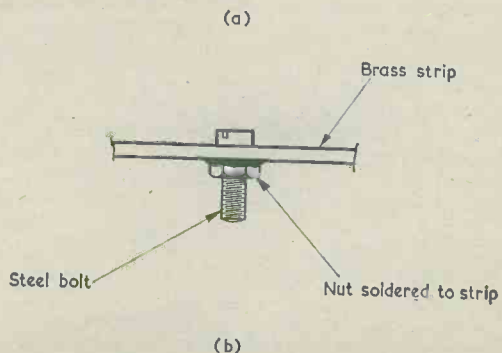

Fig. 3(a). Detail illustrating how connection is made to the lower brass strips. A similar method is employed for the upper strips

(b). Brass nuts may be soldered to the lower strips instead of using tapped holes. The nut is temporarily held in place by a steel bolt during soldering



case. This may be fitted with a metal lid having small holes through which the short-circuiting studs can pass. The dimensions shown are intended merely as a guide, and the experienced constructor will be able to adapt whatever material he has on hand or can obtain cheaply to make up the board. Obviously, a different number of vertical or horizontal strips may be employed to meet individual requirements.

The strips are held in position by a 4BA nut and bolt at each end; a further nut and two washers being added to the bolt at one end to act as a terminal for the aerial or receiver connection. See Fig. 3(a). To ensure that all the intersection holes coincide dimensionally, a good plan consists of mounting all the brass strips on the Paxolin and then drilling the intersection holes right through with a tapping-size drill. The assembly is taken apart again and the holes in the upper strips and the Paxolin are drilled out clearance size, whilst the holes in the lower strips are tapped.

Brass strip about  $\frac{1}{8}$  in. thick will be adequate for the upper strips. The lower strips need to be at least  $\frac{1}{4}$  in. thick if they are to retain the tapping satisfac-

torily. Alternatively, thinner strips can be employed with suitable brass nuts soldered to them as in Fig. 3(b). In this case, all the holes are initially drilled out clearance size. Each brass nut is then temporarily held in position for soldering by a steel bolt which should not, if care is taken, be itself soldered during the soldering operation.

The short-circuiting studs shown in Fig. 1(b) may be made up of 2BA studding. It should be possible to find old terminals in a reasonably well-stocked spares box which will provide the requisite insulated heads. An alternative approach consists of using OBA studding, with holes in the brass strips and Paxolin to match. OBA studding has an outside diameter of 0.236 in. and will take small control knobs intended for  $\frac{1}{4}$  in. shafts. It will be advisable to have the strips and strip spacing a little wider than the  $\frac{1}{4}$  in. suggested in Fig. 2 if OBA short-circuiting studs are used.

A final and important point is that one of the horizontal strips can, if desired, be connected to earth. It then becomes possible to earth one or more aerials at will. ■

## NOW HEAR THESE

Times = GMT

Frequencies = kHz

### ● IRAQ

Radio Baghdad has moved from 3240 to 3235 (92.74m) where it can be heard during the evenings. Also to be heard on 3960 (75.76m), both are 50kW.

### ● TANZANIA

Radio Tanzania, Dar-es-Salaam, is to be logged on 3339 (89.85m) around 1900 to 1930 sign-off weekdays. Sign-off is at 2000 weekends. Power is 10kW.

### ● LESOTHO

Radio Lesotho may often be heard from 0445 to 0500 and onwards. African music to 0500 then "You are tuned to Radio Lesotho", followed by BBC news relay. The station signs off just prior to 2000. Listen on 4800 (62.50m).

### ● UGANDA

Radio Kampala can be heard on 4976 (60.29m) at 1800 and at 2000 with identification and news in English.

### ● YEMEN

The Yemen Broadcasting Service is to be heard on 5804 (51.57m) around 1830 with Arabic-type music.

### ● PAKISTAN

Karachi may be heard with identification and newscast at dictation speed in English at 2030 on 9460 (31.76m) 10/50kW.

The British Association of Dx'ers report Radio Pakistan on 11672 (25.70m) 10/50kW with news in English at dictation speed at 2043; with English programme on 17830 (16.82m) 10/50kW and with English newscast at dictation speed on 21695 (13.83m) from 1000 to 1015 sign-off, this latter channel being a new frequency and apparent new service. BADX also report an East Pakistan clandestine transmitter heard from 1330 to 1347 and from 0130 to 0200 9850 (30.45m) announcing as "Swaadheen Bangla betaar kendra theke".

### ● ANGOLA

Emisora Official, Luanda, can often be heard on 3375 (88.89m) 10kW around 1930, when it was logged with a programme of light music including 'Warsaw Concerto'. The schedule is from 1700 to 2400 (0200 on Sundays) and the address of CR6RZ is - CP1329, Luanda.

### ● BURUNDI

La Voix de la Revolution, Bujumbura, may be logged on 3300 (90.91m) 25kW around 1920 when it was heard with a programme of African songs and music. Interference (QRM) from teletype transmitters abound on, and around, this channel - not an easy one to log. The address is - BP 1900, Bujumbura.

### ● DAHOMEY

Radiodiffusion du Dahomey, Cotonou, on 4870 (61.60m) 30kW, can often be logged around 1930, when it has been heard with African drums and songs. The address is - BP 366, Dahomey.

### ● CONGO

Kinshasa on 4880 (61.48m) 10kW, is often to be heard around 2030 with announcements in French and vernaculars followed by typical African music.

The regional station at Bukuvu on 4839 (62.00m) 10kW, has been logged with a discussion in French at 2028.

### ● QATAR

Qatar Broadcasting Service can be heard on 9570 (31.35m) 100kW from around 1725 to 1930 sign-off. Programme features Arabic talks and music with news in Arabic at 1730 and 1900. The address is - Qatar Broadcasting Service, Govt. of Qatar, Dept. of Information, POB 1414, Doha. (BADX)

### ● COLOMBIA

HJCQ Radio Nacional, Bogota, may be heard as late as 0550 on the regular channel of 4955 (60.54m) 50kW with a newscast in Spanish.

### ● DOMINICAN REPUBLIC

HIFA Voz de las Fuerzas Armadas, Santo Domingo, puts a good signal into the U.K. and can be heard on 4825 (62.18m) 1kW. Sign-off 0500.

Acknowledgements: BADX, Our Listening Post.

THE RADIO CONSTRUCTOR



# DIODE AND TRANSISTOR TESTERS

by  
D. SALMON

Two inexpensive testing devices for the quick checking of diodes and transistors

**N**OW THAT SURPLUS UNTESTED DIODES AND TRANSISTORS are available in bulk quantities it becomes desirable for the home-constructor and experimenter to devise simple test gear so that these devices can be checked quickly under 'go-no-go' conditions. A number of testing circuits have appeared in this journal recently, and the writer would like to introduce the two circuits to be described here as representing a further approach to the problem. They have the advantages of simplicity and of enabling tests to be carried out at high speed.

## DIODE TESTER

The first of the circuits appears in Fig. 1 and is intended for checking diodes. If a serviceable diode is connected to the test terminals with correct polarity the 'Forward' bulb lights up. If it is connected with incorrect polarity the 'Reverse' bulb lights up. The inclusion of the 'Reverse' bulb in the circuit has the advantage of allowing the polarity of unmarked diodes to be found.

If both bulbs light up the diode under test is short-circuit, and if neither bulb lights up the diode under test is open-circuit.

The a.c. voltage provided by the mains transformer should be 6.3 volts r.m.s., and both bulbs can be low consumption types such as the 6 volt 60mA

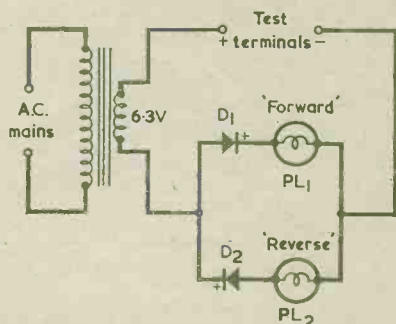
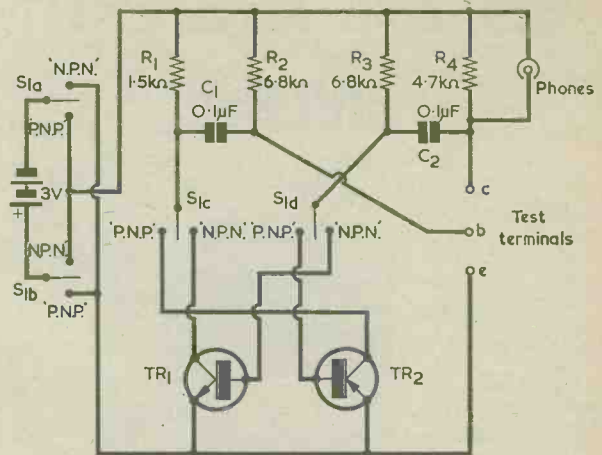

Fig. 1. The diode tester. This checks for polarity, short-circuit and open-circuit



S1d-d: 4-pole spring-loaded centre-off  
R<sub>1</sub>-R<sub>4</sub>: 1/4 watt 10%

Fig. 2. The transistor tester. The transistor being checked enters a multivibrator circuit

available from Home Radio under Cat. No. PL7. D1 and D2 can be any small silicon diodes. A suitable type is the Lucas DD000.

The writer has successfully used this tester for a variety of diodes, these ranging from small ex-computer types to 2 amp and h.t. rectifiers.

## TRANSISTOR TESTER

The second tester to be dealt with is for transistors, and its circuit appears in Fig. 2.

As may be seen, the transistor under test is connected into a multivibrator circuit, the complementary transistor (TR1 or TR2) being an integral part of the tester itself. If the transistor under test is serviceable the multivibrator operates and a tone at around 1kHz is heard in the headphones, which should be high resistance 2,000Ω types. Alternatively, the output can be connected to an a.f. amplifier driving a speaker, whereupon the requisite d.c. supply for the collector of the transistor under test is provided by R4.

Switch S1 is a spring-loaded centre-off component. When it is set to 'N.P.N.' the positive terminal of the battery connects to the upper supply line and the n.p.n. transistor TR1 is brought into circuit. With the switch in the 'P.N.P.' position the negative terminal of the battery is connected to the upper supply line and the p.n.p. transistor TR2 comes into use. TR1 and TR2 can be any n.p.n. and p.n.p. transistor respectively.

Originally, the writer employed a 9-volt battery. However, this is liable to cause the reverse base emitter voltage rating of some transistors to be exceeded, and it is better to work with the 3-volt supply shown.

The test socket for the transistor under test consists of a B7G valveholder, with pin 4 for the base connection, pins 1, 2 and 3 joined together for the emitter and pins 5, 6 and 7 joined together for the collector. This is suitable for various shapes and sizes of transistors and for different lead-out lengths. ■

# A.C./D.C. MYSTERY BULB

by  
A. L. CHIVERS

A minor enigma in electronics

THE QUANTITIES INDICATED BY OUR TESTMETERS DO not always reveal the full truth. Here is an example, easy to try out, where a voltmeter quite obviously tells a false story about the voltage appearing across a pilot lamp. This little experiment also helps to explain why some resistors in practical working circuits get hotter than we expect them to.

## CIRCUIT DETAILS

To start off with, make up the simple circuit shown in Fig. 1. The voltmeter is a moving-coil instrument which is nominally 0-5V, but any moving-coil voltmeter or multi-testmeter capable of reading 5V or 10V f.s.d. will do. The pilot lamp is a 6V 0.06A bulb, and the 3V battery can be any type. A 4.7Ω resistor can be used instead of the 5Ω fixed resistor. The 10Ω potentiometer is a wirewound component, and a suitable item is sold by Home Radio under Cat. No. VR22A. Applied to the series combination of the 5Ω resistor and 10Ω potentiometer is 6.3V a.c., this being obtained from a heater secondary on any valve mains transformer.

First, check out the circuit with the slider of the potentiometer at the bottom end of its track. Under this condition the bulb will glow dimly and the voltmeter will indicate 3V. Then, gradually move the slider along the potentiometer track until it is eventually at the end which connects to the 5Ω resistor. This process will cause the bulb to gradually brighten until, at the end, it is about three times brighter than it was at the start. Yet all the time the voltmeter continues to indicate 3V!

The same effect will be given, although not quite so dramatically, by the circuit in Fig. 2. This saves the necessity of obtaining a special potentiometer and makes it more likely that the necessary compon-

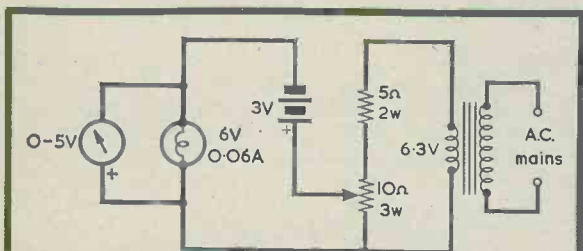

Fig. 1. A simple circuit which demonstrates an apparent anomaly in voltmeter indications

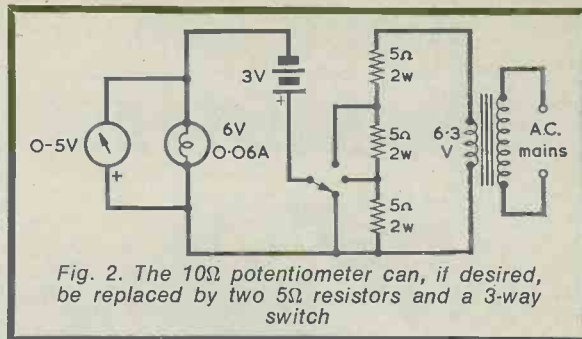

Fig. 2. The 10Ω potentiometer can, if desired, be replaced by two 5Ω resistors and a 3-way switch

ents will be on hand. As the 3-way switch moves from its bottom contact to its top contact the bulb brightness increases, again with no change in voltmeter reading. The three resistors may be 4.7Ω instead of 5Ω if this value is not available.

## HIDDEN R.M.S. CURRENT

The reason behind this little mystery is that the r.m.s. or 'heating' value of the a.c. adds to the heating current provided by the battery. Both the alternating current and the direct current flow through the bulb.

The voltage waveform appearing across the bulb when the potentiometer is tapping off about 2V peak-to-peak is shown in Fig. 3. The average value of this waveform is still 3V because the downward-going half-cycles, when they are present, subtract from the 3V potential just as much as the upward-going half-cycles add. The voltmeter indicates average voltage, which is why it remains at its 3V reading despite the fact that the bulb gets considerably brighter.

Reverting to Figs. 1 and 2, the values of resistance and the bulb current rating are just sufficiently low to enable the effect to be demonstrated adequately. If the bulb has a higher current rating it will draw too much current from the potential divider across the 6.3V secondary. The unequal current drain on alternate half-cycles will then result in an asymmetric alternating voltage at the bulb, and the two sets of

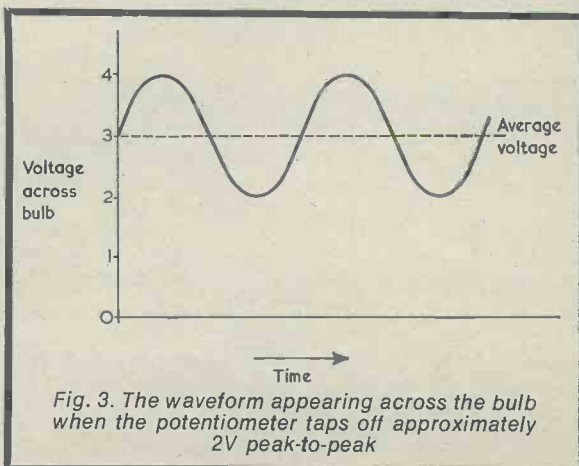

Fig. 3. The waveform appearing across the bulb when the potentiometer taps off approximately 2V peak-to-peak



half-cycles at the bulb will not balance each other out as efficiently. The meter will then suffer a noticeable deflection. With the present values, any meter deflection that occurs due to unequal half-cycles will be negligibly small.

So, if ever you encounter a resistor that seems to be running unaccountably warm despite the apparently low direct voltage that your voltmeter tells you exists across it, start looking for the alternating voltage that may also be applied to it. ■

## BERLIN INTERNATIONAL RADIO EXHIBITION 1971

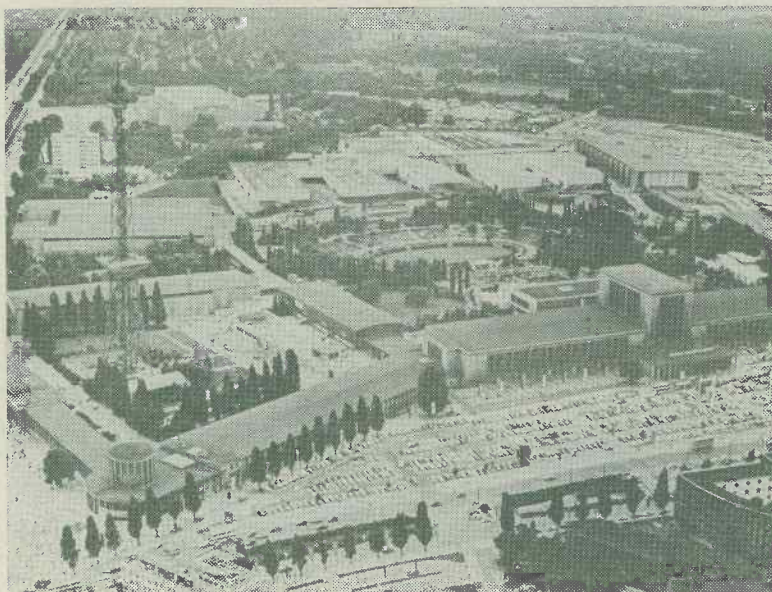

*This is the Messegelände in Berlin specially enlarged for the Radio Exhibition. In the background can be seen the six new pavilions finishing with the great Pavilion No. 1, in which the opening show will take place on the evening of the 26th August. With the additional 25,000 square metres of the new buildings, the Radio Tower site now comprises an indoor ground floor area of 88,000 square metres*

The exhibition will be held from 27th August to 5th September. There are 250 exhibitors from 15 countries, including the U.K., taking part.

## CATALOGUE RECEIVED . . .

LST Electronic Components Ltd., 7 Coptfold Road, Brentwood, Essex.

The 1971 catalogue is produced in an easy to read and concise style and contains details of many of the latest developments in semiconductor and component technology. For example, the catalogue contains details of some of the first thick film circuits ever offered to the retail public.

LST are authorised distributors for International Rectifier and Newmarket Transistors and due prominence to the ranges of these important manufacturers is given.

Besides an extremely wide range of popular transistors and diodes, the company offers a new range of encapsulated bridge rectifiers, Triacs and SCR's, varicap diodes, etc. etc.

Great prominence has been given this year to integrated circuits and LST now stock the largest range of integrated circuits available to the home constructor.

Also of particular interest is the 20 watt hybrid amplifier from Toshiba of Japan, and the popular Hardcastle and Lane 15 watt amplifier is offered in kit form at a remarkably low price.

Having specialised for many years in opto electronics, the company has this year added several new items to its range including some very low cost gallium arsenide light sources and planar silicon photo transistors.

Five pages of the catalogue are devoted to capacitors of various types, and the company informs us that their stock of Mullard capacitors is extremely good.

A minor item of interest is the new LS14G neon by Russenberger (for whom LST are franchised distributors). This is the only indicator on the market with an arrow shaped face which should be ideal for electronic games, etc.

The final page of the catalogue is devoted to the popular LST data service, and the company informs us that the demand for information during the last twelve months has exceeded all expectations. Literally thousands of data sheets being sent out every month.

Request for copies should be addressed to Mail Order Department RC, 7 Coptfold Road, Brentwood, Essex; the company would appreciate postage but the catalogue itself is free.



Cover Feature

# THE BAND

by  
J. B. WILLMO

A simple superhet design offering coverage from 20 to 180 metres. An aerial trim control for each coil range is split into two halves. Variable capacitors are obtained, the receiver is of medium wave



**O**F ALL THE CONSTRUCTIONAL PROJECTS WHICH CAN be undertaken by the enthusiast of average ability, the design and assembly of short wave receivers continues to hold pride of place for popularity, as a glance through back numbers of this magazine will quickly show. The author therefore makes no apology for introducing yet another short-wave receiver design, especially as the set to be described incorporates several novel features.

## FEATURES OF THE DESIGN

Although using only two valves (excluding the power supply unit which can be either the "bench" power supply or the simple add-on unit described herein), the full advantages of sensitivity and selectivity associated with a superhet receiver are realised, yet there are no reflex or other "gimmick" circuits which so often cause problems of instability or erratic operation when attempts are made to reproduce such circuits under amateur constructor conditions. Most of the simpler short wave receivers are of the t.r.f. type and a surprisingly high degree of sensitivity can be achieved with these but, owing

to the reliance placed on critically designed and adjusted regenerative detector circuits, such receivers tend to be somewhat tricky to operate if optimum results are desired.

The superior station-getting "pull" of a superhet and its inherently better selectivity are unchallengeable; but there is one feature in which a well designed t.r.f. short wave receiver can claim superiority, namely that of the signal-to-noise ratio. The conventional superhet receiver, working at a high level of audio output into a loudspeaker, does tend to be bedevilled by an unduly high level of background noise. Efforts to hear the weaker transmissions by advancing the a.f. gain control result in an ear-splitting level of static, crackles and hiss.

But why endeavour to operate a loudspeaker for short-wave listening, anyway? The purpose of a loudspeaker is primarily that of allowing a number of persons to listen simultaneously in the domestic living room; this is a requirement seldom met with in serious short wave listening. The present receiver is therefore designed for headphone reception, and only a modest degree of a.f. amplification is provided; whereupon it also becomes possible to use a lower h.t. supply voltage (about 180V) with a consequent reduction of noise generation in the frequency changer and i.f. amplifier stages, yet with no appreciable reduction in overall sensitivity.

A further important requirement of a short wave receiver is reliable slow motion tuning over the crowded broadcast and amateur wavebands. This is dealt with in two ways in this receiver.

First of all, an epicyclic ball type reduction drive is fitted to the main 2-gang tuning capacitor, which in conjunction with a large scale and pointer giving 0-180 degree sweep, renders calibration showing the principal short wave bands a simple matter. The author used a dial and drive of unknown make bought cheaply at a "junk box sale", but it is not difficult to make up a simple scale protected by a spaced-off Perspex sheet and using a length of wire as a pointer. An-

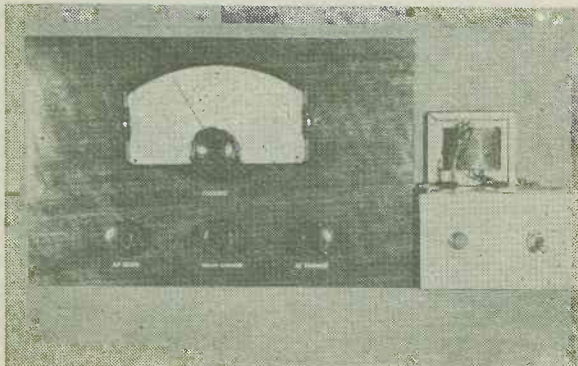

Front view of the receiver and power supply



# DMASTER

ST, A.I.P.R.E.

verage of the short wave bands from  
l is provided and, for ease of tuning,  
es. If the requisite coils and padding  
can also provide coverage of the  
ave band

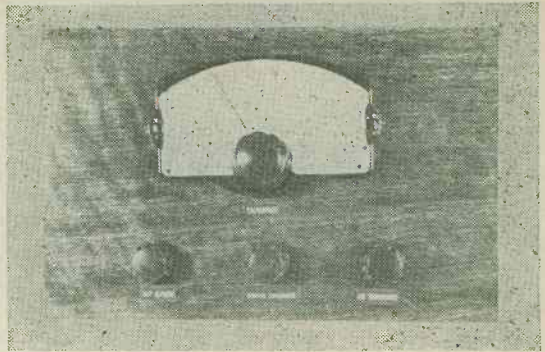

other alternative would be the Eagle vernier dial type T502, available from Henry's Radio. This would, of course, impart a different appearance to the front panel.

Secondly, the specified tuning coils, chosen from the popular Denco dual-purpose range, require a tuning capacitance of 300pF nominal. Here, a 160pF component is used, so that the swing from 0° to 180° covers approximately half the normal waveband range of the coils in use. By operating the Bandspread Switch provided, additional close tolerance fixed capacitors of 150pF are placed in parallel with each section of the main 2-gang tuning capacitor, whose effective variation thus becomes some 160 to 310pF, and thus covers the second half of the waveband for which the coils were designed. In practice, there will be a slight overlap, in other words stations found near the fully clockwise position of the tuning dial with the bandspread switch in the "off" position, will re-appear at the anti-clockwise end of the tuning dial when the bandspread switch is "on"; but this is no drawback, and it does ensure continuous coverage. This simple form of electrical bandspread has the effect of doubling the length of the tuning scale, and so easing the separation of closely crowded transmissions.

Use of Denco coils for Ranges 3 and 4 will enable the whole of the short wave and shipping band from approximately 20 to 180 metres to be covered. The coils are used in their plug-in application, employing B9A valveholders and thus dispensing with elaborate wavechange switching. Plugging in the oscillator coil for a given range automatically ensures that the correct value of padder capacitor is brought into circuit. Using Range 3 and Range 4 Blue and Red coils, with the appropriate i.f. of 465kHz, the following approximate coverage will be obtained:

Band 1. 20 - 43m.

Range 4 coils, bandspread switch "off"

Band 2. 37 - 60m.

Range 4 coils, bandspread switch "on"

Band 3. 57 - 120m.

Range 3 coils, bandspread switch "off"

Band 4. 115 - 180m.

Range 3 coils, bandspread switch "on"

When the receiver has been completed, tested and aligned, the positions of the principal reception bands can be marked on the tuning dial, or a logging chart drawn up showing dial positions in terms of 0°-180° against wavelengths or frequencies, for each of the above bands, 1 to 4.

If desired, medium waveband coverage can also be included by the use of Range 2 (194 to 580m) coils and the appropriate 350pF padder capacitor wired between pin 2 of the oscillator coilholder and chassis. This was done in the prototype.

One further refinement is included. A "fine tuner" in the form of a 0-50pF variable capacitor is wired across the aerial tuning section of the main 2-gang tuning capacitor. This enables any slight irregularities in the tracking of the aerial and oscillator tuning circuits to be corrected at all settings of the tuning dial, and a surprisingly worthwhile increase in sensitivity, especially when searching for a weak signal, will be found to result.

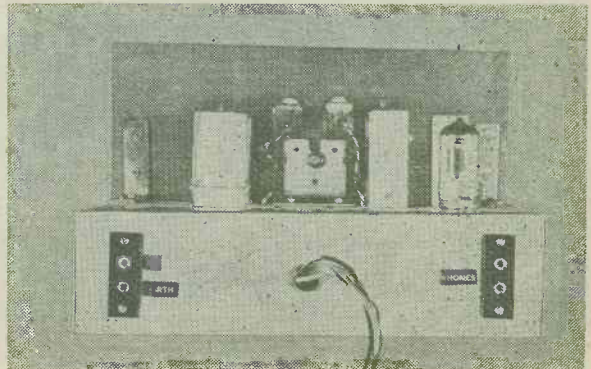

The rear of the receiver

## CIRCUIT DESCRIPTION

Before proceeding with constructional details, a brief description of the circuit, which is shown in Fig. 1, will not be out of place.

V1 is an ECH81 triode-heptode valve whose performance as a frequency changer is of a very high standard; valves of this type combine a high conversion conductance ("gain") with a low noise level. Signals are fed to the control grid of the heptode section of this valve by the tuned circuit given by L1 and VC1 in parallel with the "fine tuner" VC3 and, of course, the pre-set trimmer TC1. The oscillator section of V1 is of the tuned grid type; L2 and VC2, together with trimmer TC2 and paddler CP1 or CP2, provide the necessary tuning, trimming and padding facilities. Feedback is provided via the tuned winding of L2, and the h.t. voltage, dropped to a suitable level by R4 (and decoupled by C4), is fed to the oscillator anode of V1. The screen-grid of V1 is fed from the h.t. positive line via R1 (decoupled by C1) and is held at a potential of approximately 70 volts; it was found that whilst a reduced value for R1, and hence a higher voltage on the screen-grid, gave increased gain, there was a sharp rise in noise level. The specified value of R1 (47k $\Omega$ ) seemed the best compromise.

Fixed bias for V1 is provided in the usual manner by the inclusion of R2 and C2 in the cathode circuit. The i.f. signal, at 465kHz, is picked off at the anode of the mixer section of V1 by the tuned primary winding of the first i.f. transformer IFT1 and, via the secondary winding thereof, applied to the control grid of the i.f. amplifier. I.f. amplification is pro-

vided by the pentode section of V2, which is an ECF80 triode-pentode valve. Experiments made with varying values of cathode bias resistor (R8) and screen grid voltage dropper resistor (R5) finally settled on the values shown as giving maximum gain consistent with freedom from instability.

A further i.f. transformer, IFT2, also of course tuned to resonate at 465kHz, transfers the signal from the anode of V2(a) to the second (triode) half of the valve V2(b). This latter is used as a grid leak detector. Whilst this form of detection is a little unusual these days (except in the simpler t.r.f. type of receiver) it has several useful features. It is more sensitive to weak signals than the more familiar diode, and it also provides a very useful degree of a.f. amplification, so much so that no further stage of a.f. amplification is required to provide adequate output for headphone listening. There are, however, certain minor drawbacks; there is a degree of loading imposed on the secondary tuned winding of IFT2 (minimised by the judicious choice of values for C7 and R7); also there is a tendency for this type of detector to overload on very strong signals, but in a receiver such as this, designed primarily for short wave listening, overloading is hardly likely to be a serious problem.

Another factor is that an a.g.c. voltage, normally a by-product of diode detection, is not readily available. However, the existence of a.g.c. for short wave listening is not altogether desirable, as variations of bias on the controlled valves, particularly the frequency changer, can lead to a degree of de-tuning on strong signals. In fact most domestic valve broadcast receivers which feature a short wave band,

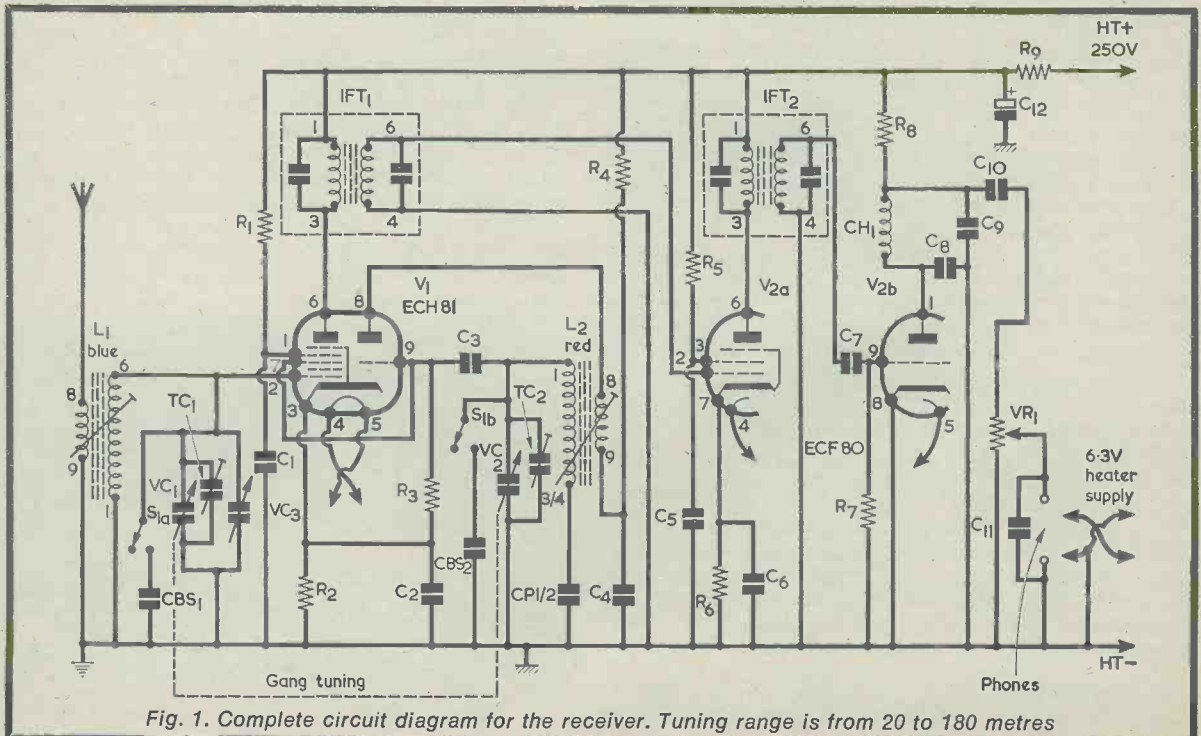

Fig. 1. Complete circuit diagram for the receiver. Tuning range is from 20 to 180 metres



## COMPONENTS

### Resistors

(All fixed values  $\frac{1}{2}$  watt 10% unless otherwise stated)

- R1 47k $\Omega$
- R2 220 $\Omega$
- R3 47k $\Omega$
- R4 22k $\Omega$
- R5 33k $\Omega$
- R6 330 $\Omega$
- R7 1M $\Omega$
- R8 100k $\Omega$
- R9 2.2k $\Omega$  5 watt wirewound (see text)
- VR1 1M $\Omega$  potentiometer, log

### Capacitors

(All fixed values 350V wkg.)

- C1 0.1 $\mu$ F, paper or plastic foil
- C2 0.1 $\mu$ F, paper or plastic foil
- C3 100pF, silver-mica
- C4 0.1 $\mu$ F, paper or plastic foil
- C5 0.1 $\mu$ F, paper or plastic foil
- C6 0.1 $\mu$ F, paper or plastic foil
- C7 100pF, silver-mica or ceramic
- C8 100pF, silver-mica or plastic
- C9 100pF, silver-mica or plastic
- C10 0.1 $\mu$ F, paper or plastic foil
- C11 0.002 $\mu$ F, paper or plastic foil
- C12 2 $\mu$ F, electrolytic
- CBS1 150pF, silver-mica, 1%
- CBS2 150pF, silver-mica, 1%
- CP1 3,000pF, silver-mica, 1%
- CP2 1,000pF, silver-mica, 1%
- TC1 50pF trimmer, mica
- TC2 50pF trimmer, mica
- VC1, VC2 160 + 160pF, 2-gang variable (see text)
- VC3 50pF, variable, air-spaced

### Inductors

- L1 Miniature Dual-Purpose (valve) coil, Blue, Range 3, and similar Range 4 (Denco)
- L2 Miniature Dual-Purpose (valve) coil, Red, Range 3, and similar Range 4 (Denco)
- IFT1 Miniature i.f. transformer type IFT11 465kHz (Denco)
- IFT2 Miniature i.f. transformer type IFT11 465kHz (Denco)

CH1 1.5mH r.f. choke

### Valves

- V1 ECH81
- V2 ECF80

### Switch

S1(a)(b) 2-pole 2-way switch, rotary

### Sockets

- 2 B9A valveholders
- 2 B9A valveholders, with skirts
- 1 Aerial/Earth socket strip
- 1 Phones socket strip

### Miscellaneous

- 1 tuning drive and dial (see text)
- 3 small control knobs
- 1 4-way tagstrip, end tags earthed
- 2 7-way tagstrips, end tags earthed (see text)
- 2 2in. x 2in. angle brackets
- 1 supporting bracket for VC1/2
- Material for chassis and front panel
- Wire, sleeving, solder tags, grommets, etc.

*Additional Components for Power Supply  
(if required)*

### Resistors

- R10 56k $\Omega$  2 watt, carbon
- R11 1.2k $\Omega$  3 watt, wirewound

### Capacitors

- C13 0.01 $\mu$ F, paper or plastic foil, 350V wkg.
- C14(a)(b) 32 + 32 $\mu$ F, dual electrolytic capacitor, 350V wkg.

### Transformer

T1 Mains transformer, secondaries 230 to 240 volt, 40mA; 6.3 volt, 1.5A

### Switch

S2 s.p.s.t., toggle

### Rectifier

D1 BY100

### Pilot Light

PL1 6.3 volt pilot lamp complete with holder

### Miscellaneous

- 4-way connector block
- Material for chassis (as required), wire, solder tags, etc.

short-circuit the a.g.c. line to chassis when switched to short waves!

Returning to consideration of the circuit, the demodulated and amplified a.f. signal appearing at the anode of V2(b) is filtered of residual r.f. by r.f. choke CH1 and capacitors C8 and C9. R8 is the anode load, and the signal is parallel fed to the output potentiometer (a.f. gain control) VR1 via the d.c. blocking capacitor C10. The headphones, connected between the slider of VR1 and the chassis line, are thus completely isolated from the h.t. positive line. The value specified for VR1 (1M $\Omega$ ) may seem high when it is considered that the output load is a pair of headphones. In practice, VR1 works well with 2,000 $\Omega$  phones. A capacitor, C11, is connected across the headphone output sockets to provide a small degree of "top cut" correction.

AUGUST 1971

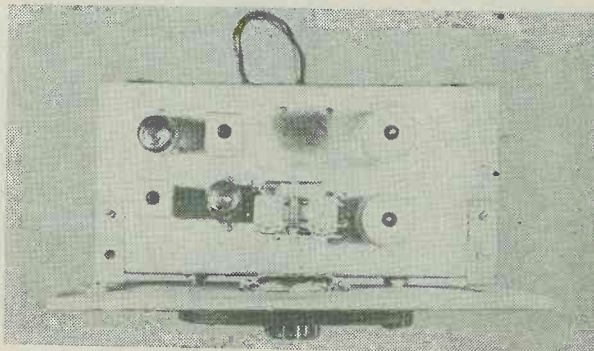

*Top view, showing the components above the chassis*

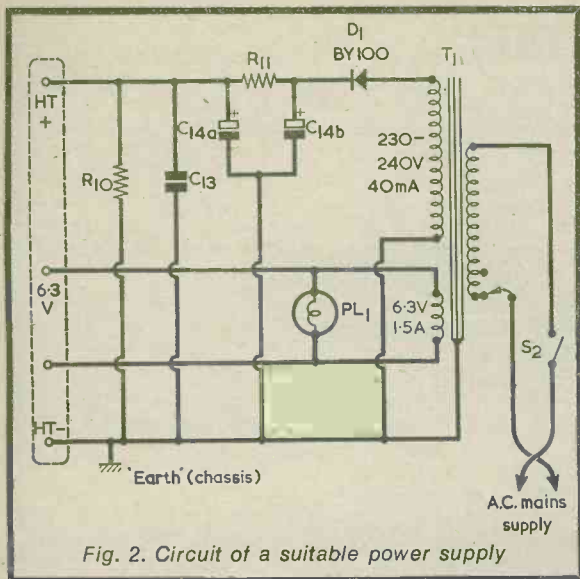

## POWER SUPPLY

The original receiver was designed to operate from an existing "bench" supply but, for convenience, a small self-contained power supply unit, using the circuitry of Fig. 2, was subsequently assembled. It is vital that the power supply *must* be completely isolated from the mains by the use of a double-wound mains transformer; *on no account* should this receiver be operated from a half-wave power supply source of the type having the h.t. negative line and chassis connected directly to one side of the mains supply.

It will be observed that the h.t. positive voltage from the power unit passes through a further stage of filtering, provided by R9 and C12 mounted on the receiver chassis; R9 also serves to drop the h.t. line voltage in the receiver to the region of 180V. It may be necessary to try different values of R9 to obtain this voltage, although it is by no means critical.

The inclusion of R10 and C13 should be noted. These components are not always present in power supply unit circuits, but are well worth while including. The purpose of C13 is to provide a low impedance path for any r.f. signals which may still be present on the h.t. positive line, thus obviating the danger of unwanted back-coupling and possible instability in the frequency changer and i.f. stages. R10 acts as a bleeder resistor, and ensures that the power supply unit h.t. capacitors quickly discharge when the unit is switched off (for coil changing, for example). It also assists in regulation of the h.t. supply voltage under varying load conditions.

Mains transformers offering 230 to 240V at 40mA and 6.3V at 1.5A are readily available, a suitable type being the Osmabet component available from Home Radio under Cat. No. TM26A.

## CONSTRUCTION

The prototype was constructed on a four-sided aluminium chassis measuring 9½ by 4½ by 2½ in. Full drilling and component layout details are given

in Fig. 3, and reference to the photographs of the completed receiver should provide any further information that is required. The method of affixing the wooden front panel to the chassis, using 2 by 2 in. angle brackets, is also clearly shown in the photographs. The panel employed for the author's model measured 9½ by 6 in., but constructors can make the panel to alternative dimensions if they wish. Should it be desired to provide a cabinet, one must be assembled which has an opening lid to give easy access for changing the plug-in tuning coils when required. No cabinet details are given, as this can be left to the discretion (and ability level!) of the constructor.

No drilling dimensions are shown in Fig. 3 for the mounting of VC1/VC2, as these will depend on the actual component purchased. It may prove difficult to obtain a 2 x 160pF variable capacitor, and a 2 x 176pF component will be satisfactory instead; the only result will be a wider overlap between the wavebands covered. Most components of this sort require to be mounted on a small bracket, which can be easily made from a small piece of scrap aluminium. This also can be seen in the photograph. The mounting of the trimmer capacitors TC1 and TC2 on this bracket should also be noted. The section of the ganged capacitor nearer the front of the chassis is for aerial tuning (VC1).

It is important that the valveholders, including those used as coilholders for L1 and L2, should be correctly orientated as shown in Fig. 3. The arrow in the diagram points to the gap between pins 1 and 9. The valveholders for V1 and V2 are skirted types. A useful scale drawing is enclosed with the Denco coils when purchased, showing how to utilise the lid and body of the cans in which the coils are packed as screening cans.

The drilling pattern shown for the i.f. transformers (assuming that the specified Denco transformers are employed) will ensure that these are correctly orientated. Pin 3 of each transformer should be nearer the valve anode pin to which it connects.

It will be noted that there are four holes for two 7-way tagstrips. These should have outer tags earthed only. The tagstrips employed by the author were flat types and were secured by passing mounting bolts through the end tag holes, suitable spacing washers being fitted. It would be in order, alternatively, to employ 7-way tagstrips in which the central and two outer tags are earthed, cutting away the mounting section of the centre tag. There is also a 4-way tagstrip; this has its outer tags earthed. In

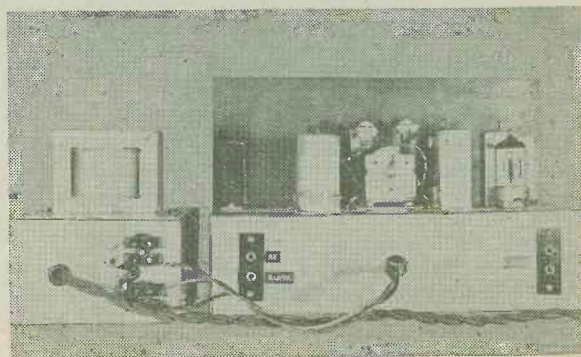

The receiver coupled up to a suitable power supply

THE RADIO CONSTRUCTOR



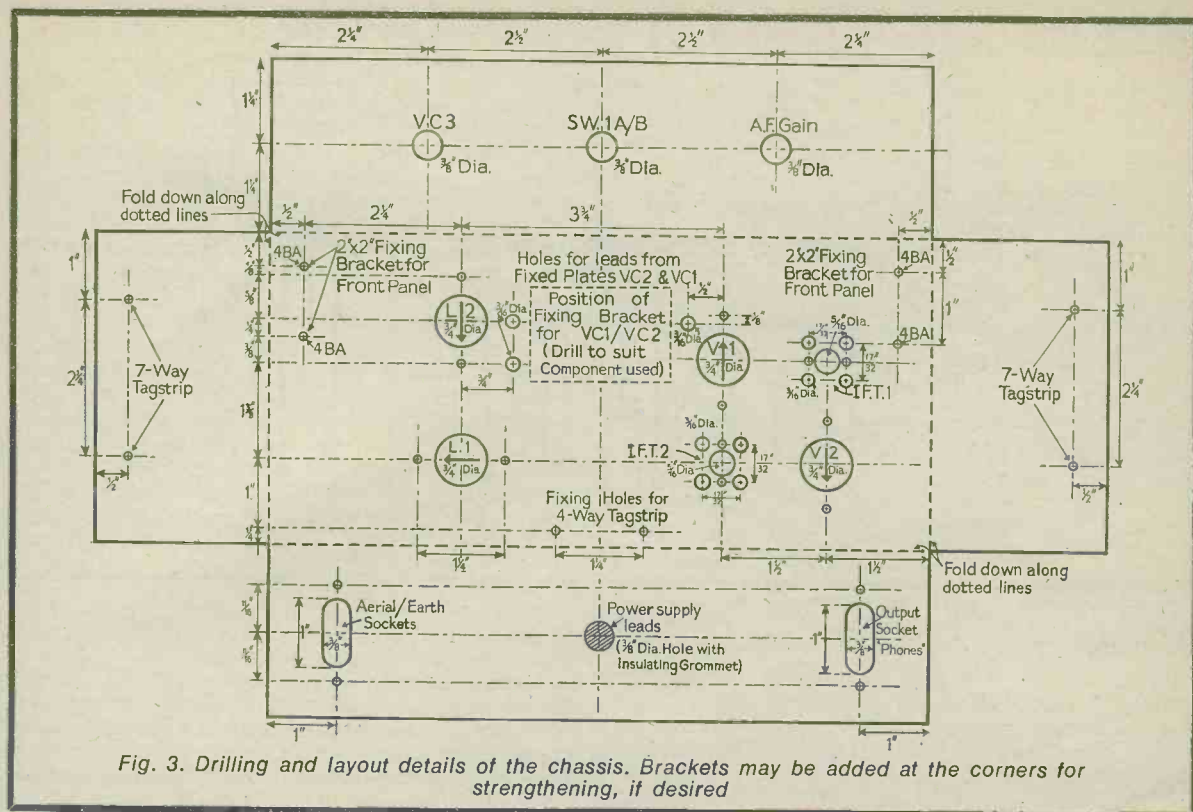

Fig. 3. Drilling and layout details of the chassis. Brackets may be added at the corners for strengthening, if desired

all cases, and before drilling, check the tag mounting hole positions indicated in Fig. 3 against the actual tagstrips to be used. If the required hole positions differ slightly from those shown in Fig. 3, re-dimension accordingly.

Similar comments apply to the aerial/earth and output sockets. Before drilling, check against the actual components to be used and, if necessary, re-dimension the mounting holes as needed.

A major constructional feature of this receiver, and one which greatly eases the problem of obtaining neat yet direct wiring of the various resistors and capacitors, is the use of two tinned copper wire "busbars" stretched across the entire length of the chassis, one forming the "h.t. positive" line and the other the "earth" line. This feature is clearly visible in the photograph of the underside of the completed receiver, where it will be seen that the busbars connect between the two 7-way tagstrips just referred to. The "earth" busbar is insulated from the chassis at both its end fixing points, and is connected to the earth socket, and also the chassis of the receiver, at this single earthing point.

It is recommended that the heater supply wiring be completed first, using twisted twin flex laid close to the chassis surface; one side of the heater supply should be earthed, and this may conveniently be done at the four-way tagstrip to which the power supply leads are anchored near their point of entry into the chassis through the grommeted hole in the rear chassis runner.

Next wire up the signal path circuits, commencing with the aerial input, and then, referring to Fig. 1, working progressively through the circuit via L1,

IFT1, L2, IFT2, V2(b), etc., not forgetting the "bandsread switch" and its attendant capacitors CBS1 and CBS2. These capacitors are brought into circuit when the spindle of the switch is turned clockwise. Short and direct wiring is essential in all signal-carrying circuits. The remaining components, which are the various voltage dropping resistors, bias resistors and decoupling capacitors, may then be wired in. All these originate from the "h.t. positive" or "earth" busbars. Fig. 4 clearly shows in an exploded form the method of carrying this out. Note that not all the tags on the anchoring tagstrips to which the busbars are secured are utilised, the tags used were chosen as they gave a convenient degree of physical separation between the two busbars. Insulated sleeving is used on the h.t. busbar between the soldering points of the various components secured thereto.

Where chassis connections are not made to the "earth" busbar they may be taken to conveniently positioned chassis solder tags. Thus, pins 1 and 9 of coil L1 connect to a chassis solder tag secured under the adjacent coilholder securing nut. Solder tags under one of the mounting nuts similarly provide chassis connections at the two socket strips.

Detailed layout plans of the power supply unit are not given since, as mentioned earlier, many constructors may already have a suitable unit in existence. In any case, the circuit shown in Fig. 2 can be reproduced with any convenient layout. It is advisable to provide the output terminations in the form of a four-way connector block. Colour coded flexible leads from the receiver may then be quickly connected to the unit as required.

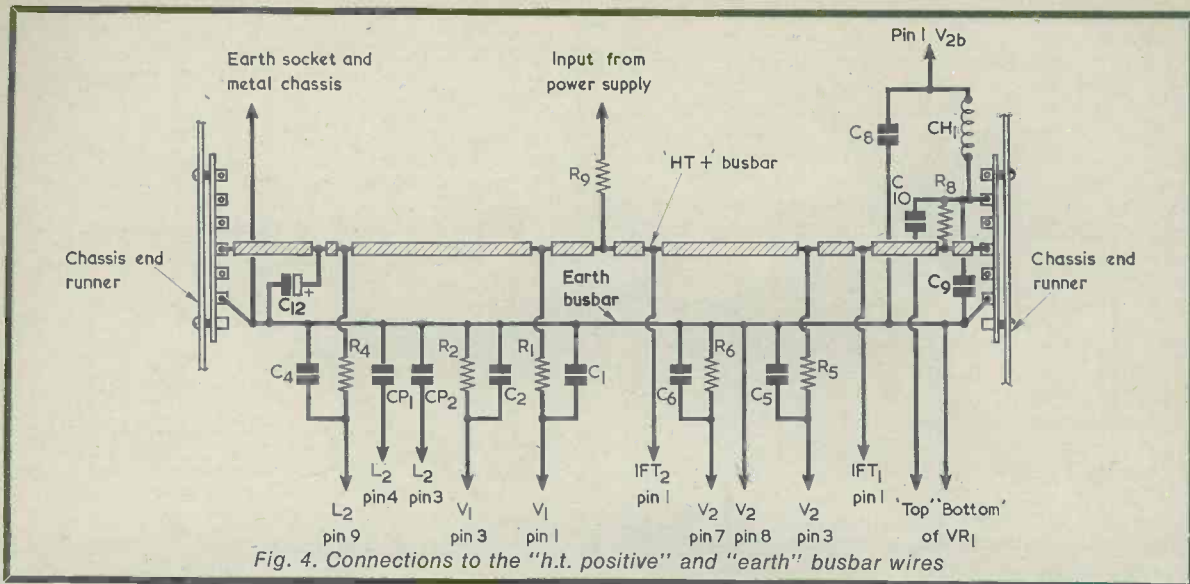

Fig. 4. Connections to the "h.t. positive" and "earth" busbar wires

### ALIGNMENT

When the receiver has been completed, and the wiring carefully checked, together with the usual tests with an ohmmeter to ensure the absence of wiring errors leading to short-circuits between h.t. positive and chassis, alignment of the i.f. and r.f. circuits must be carried out. Whilst it is feasible to align a superhet receiver to a reasonable performance level without a signal generator, and means of doing this have appeared in these pages in the past, this demands great patience. The use of a signal generator, if necessary borrowed for the occasion from a fellow enthusiast, renders the whole process much simpler and will ensure optimum results. Assuming, then, that a signal generator is available the following procedure is recommended.

Connect the signal generator to the mains supply, switch on, set the dial to 465kHz, and the output indicator to "modulated r.f." at a fairly high setting of the attenuator, and allow at least ten minutes for the generator to warm up. Whilst waiting, insert Range 3 coils - blue in the L1 and red in the L2 position - and screw on the coil screening cans. Temporarily connect a 0.1μF capacitor across VC2; this will render the oscillator section of V1 inoperative during the alignment of the i.f. transformers. Plug headphones into the output sockets of the receiver. Using the "plain" output (i.e. not the dummy aerial terminal if one is provided) from the signal generator, connect the inner conductor of the output lead to pin 2 of V2(a) and the outer to the "earth" busbar. Connect the power supply to the receiver and switch on. Set the a.f. gain control at maximum. Adjust the output attenuator on the generator until the i.f. signal is just comfortably audible in the phones. Using an insulated trimming tool, carefully adjust the cores of IFT2 until maximum response is heard, continually reducing the output level of the generator as required to maintain a low level of volume so that the effects of alignment are more easily discerned.

Now disconnect the generator from V2(a) and reconnect it to pin 2 of V1. Again continually reduc-

ing its output to give a low volume level in the phones, adjust the cores of IFT1 for maximum response and then re-adjust the cores of IFT2. Repeat the adjustment of all four i.f. transformer cores. Swing the generator tuning slightly above and below the 465kHz setting, say 7kHz on either side; there should be a sharp drop in the response, evenly distributed on either side of the 465kHz datum.

When satisfied with the alignment of the i.f. transformers, remove the 0.1μF capacitor from VC2. Unscrew the trimmer capacitors TC1 and TC2, and set VC3 to half-capacitance. Set the cores of L1 and L2 so that about ½ in. of the brass stem protrudes above each coil former. Using the dummy aerial lead (if provided) connect the signal generator to the aerial and earth sockets of the receiver. If no dummy aerial output is available, couple to the aerial socket via a 100pF capacitor. Turn the receiver tuning capacitor fully clockwise (vanes fully enmeshed) and set the bandspread switch to the "on" position, bringing CBS1 and CBS2 into circuit. Set the generator to 1.7MHz, and adjust the cores of L2 and L1 (in that order) until the signal is heard at optimum strength. Now try the effect of "rocking"

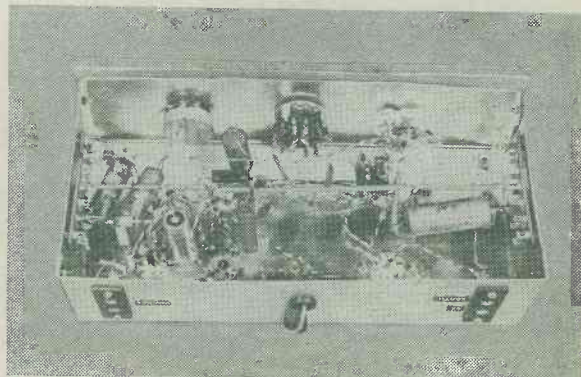

Underneath the chassis. The two busbar wires may be seen running across the chassis length



the tuning capacitor VC1/2 slightly back and forth, whereupon it may be found that a stronger response to the 1.7MHz signal can be heard at a slightly lower dial setting, in which case this is the correct dial setting for this particular frequency.

Now set the generator to 5.3MHz, turn the bandspread switch to the "off" position, and rotate VC1/2 to the fully open (anti-clockwise) position. Adjust TC2 and TC1 (in that order) for maximum response. It will probably be found that there are two settings of TC2 at which a response is obtained, the one with the trimmer screwed in the least is the correct setting.

Return the generator to 1.7MHz, the bandspread switch to "on", and VC1/2 to the previously determined setting for 1.7MHz, and re-adjust the cores of L1 and L2. Repeat these sets of adjustments for 1.7MHz and 5.3MHz several times until no further improvement can be obtained.

Now insert the Range 4 coils. Set the generator to 5MHz, bandspread switch to "on", and adjust the cores of L2 and L1 in a similar manner to that previously adopted for Range 3. Next set the generator to 15MHz, the bandspread switch to "off", and VC1/2 to approximately the fully open position; the signal should be found on or adjacent to minimum dial setting. Do *not* adjust TC1 or TC2 as this would of course invalidate the alignment already carried out with the Range 3 coils, but a slight adjustment of the panel controlled VC3 should enable the desired "peaking" of the signal to be obtained.

The receiver is now ready for use. Remember that it should be operated with the coil screening cans screwed on. These are, of course, removed to change the coils.

## OPERATION

Connect a suitable aerial and earth to the appropriate sockets. A word about aerial and earth systems for short wave work might be appropriate at this juncture. Whilst it is possible to operate the average domestic receiver satisfactorily, at any rate for local B.B.C. reception, on a few feet of wire dangling from the aerial socket or from an internal ferrite rod aerial, for effective long range short wave reception something more efficient is desirable. Ideally, an outdoor aerial, either a horizontal wire or a vertical rod type, should be used. As a reasonable substitute a loft aerial can give acceptable results in most locations.

A really good earth connection, either to a cold water pipe (if there is no plastic section between its point of entry into the house and the connection) or an earth spike driven into moist ground, also assists greatly in improving the performance of a short wave receiver. So please don't expect this receiver (or any other short wave set) to bring in Australia loud and clear on a piece of bell wire supported on the picture rail.

Naturally, the number of short wave transmissions heard on a given occasion is dependent on conditions outside the control of the operator, but the receiver described in this article is capable of really long range reception and should make an excellent introduction into the fascination of short wave listening. And if its use encourages you to invest in, or construct, a more ambitious communications type of receiver, well, why not?

AUGUST 1971

# CURRENT SCHEDULES

Times = GMT

Frequencies = kHz

## ★ CHILE

Radio Minería, Santiago, requires reports from SWL's. Operational frequencies are **6070** (49.42 metres), **9570** (31.55m) and **11970** (25.06m), all 5kW. The schedule is from 1100 to 0530, the address - CB106, Casilla 2626, Santiago.

## ★ EQUADOR

The evening schedule of HCJB Quito is now radiated over the new channels of **15415** (19.46m) and **17780** (16.87m). The early transmission to Europe is now on **6050** (49.59m).

## ★ PARAGUAY

ZPA10 Radio Paraguay, Ascuncion, identifies as "Emisora Paraguay" and can be heard on **6015** (49.88m). The evening schedule is from 2000 to 2400, the power is 1kW. Address - Av. Dr. Gaspar R. de Francia 348, Ascuncion.

## ★ SWITZERLAND

The Swiss Short Wave Service has added new channels for the service to the Far East, India and Pakistan. The English programme commences at 1315, the German at 1345, the French at 1415 and the Italian at 1445 on **15305** (19.60m), **17845** (16.81m), **21520** (13.94m) and **21725** (13.81m).

## ★ AUSTRALIA

Radio Australia can be heard with an English programme to South and South East Asia on **7235** (41.47m) in parallel with **9550** (31.41m) from 1500 to 1730.

## ★ ANGOLA

CR6RD Radio Clube do Huambo, 1kW, may be heard with news summary and music at 2250 and sign-off with the National Anthem at 2301 on **5060** (59.29m).

## ★ NEW CALEDONIA

Noumea is now reported on the new frequency of **4913** (61.04m) which replaces the old **3355** channel. Heard from 1900 to 2100 and from 0600 to 1100, in parallel with **7170** (41.84m) and **9510** (31.55m).

## ★ ETHIOPIA

ETLF Addis Ababa has been heard on **15315** (19.59m) with 'Elizabethan Serenade' interval signal and sign-on in English with a programme directed to India and Ceylon.

## ★ CZECHOSLOVAKIA

Radio Prague is currently broadcasting to the U.K. and Ireland as follows - from 1500 to 1525 on **6055** (49.55m) and on **9515** (31.53m). From 1630 to 1657 on **5930** (50.59m) and **7345** (40.85m). Also on the latter two channels from 1900 to 1927. To the U.S.A. and Canada at 0100 and 0300 on **5930**, **7345**, **9540**, **9630**, **11990** and **15365**. To the U.S.A. and Canada from 1400 to 1455 on **15445**, **17840** and **21735** on Sundays only. All programmes are of 55 minutes duration in the N. American service.

## NOTE

In response to requests from several readers, equipped with 'domestic' short wave receivers, wavelengths in metres will be included with some of the items quoted in these columns.

Acknowledgements:- Our Listening Post, SCDX ■

# COUPLING CAPACITORS CAUSES COMPLICATIONS

by

T. BURLMAN

One of the earliest of radio faults can return,  
even now, to plague the service engineer

THESE DAYS, ONE WOULD HAVE THOUGHT THAT A.F. amplifying circuits incorporating valves should have been completely overtaken by the corresponding transistor versions. But such is not the case – particularly in the author's district. If valve a.f. amplifiers do not appear as complete units in record-players or hi-fi amplifying equipments, they turn up in the a.f. stages of radio and television receivers. The a.f. amplifier valve may be obsolescent, but it's taking a dickens of a long time to become obsolete.

Owners of domestic valve equipment can hardly be blamed for not relinquishing their old valve amplifiers and receivers, which have given so much adequate and reliable service in the past. The result, however, is that these amplifiers and receivers nowadays tend to exhibit faults which are mostly the result of long hours of operation, and a service engineer begins to start looking for snags which are simply due to 'old age'. These snags largely consist of electrolytic capacitors drying out and losing capacitance, carbon resistors shifting in value and – to return to the a.f. amplifiers with which this article commenced – distortion resulting from a.f. coupling capacitors becoming leaky. The first two of these 'old age' snags are easy to locate, but the third cannot always be readily detected with ordinary test gear. It is an ironic fact, indeed, that leaky coupling capacitors in valve a.f. amplifiers can usually be traced much more easily without the use of test gear at all!

This article gives details of what to look for when checking a.f. coupling capacitors in valve amplifiers which exhibit distortion. To a small extent the remarks are applicable to coupling capacitors in transistor amplifiers as well, but the low impedance transistor is nowhere near as susceptible to the effects to be described as is the high impedance valve.

## CIRCUIT POSITION

Coupling capacitors in valve a.f. amplifiers are liable to cause distortion when they couple the anode of one valve to the control grid of the next. Fig. 1 shows the general set-up, with fairly average component values and voltages.

Now, when the coupling capacitor is in good condition its leakage resistance can be considered, for all intents and purposes, to be infinite. In Fig. 1, no direct current will then flow from the 100kΩ anode load resistor to the following 470kΩ grid resistor, and

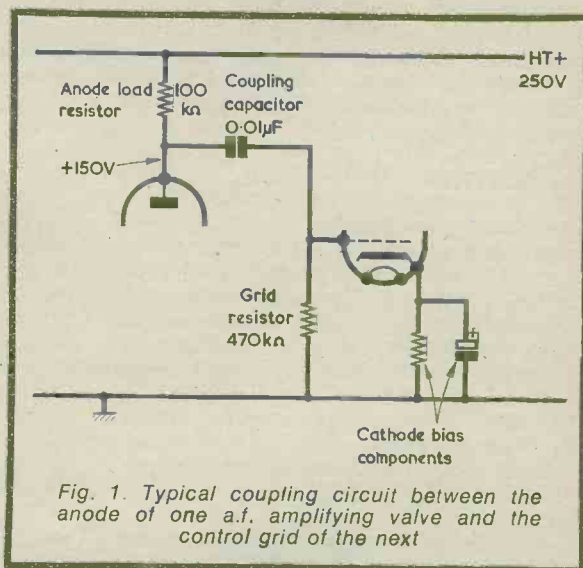

Fig. 1. Typical coupling circuit between the anode of one a.f. amplifying valve and the control grid of the next

the capacitor merely allows the passage of audio frequency signals. So far, so good. Let's next say that the coupling capacitor develops a leakage resistance, this being as high as 50MΩ. From the point of view of direct voltage the circuit becomes that shown in Fig. 2, in which the capacitor is replaced by a 50MΩ resistor. Due to anode current in the preceding valve, the junction of this 50MΩ resistor and the 100kΩ resistor at the top has a potential of about 150 volts above chassis. Following normal voltage divider principles, the voltage across the 470kΩ grid resistor at the bottom then becomes:

$$\frac{470k\Omega}{50M\Omega + 470k\Omega} \times 150 \text{ volts.}$$

This works out at approximately 1.5 volts.

THE RADIO CONSTRUCTOR



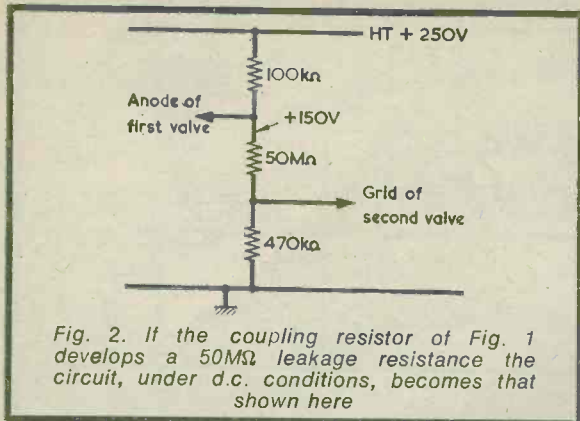

It could be thought that a leakage resistance of 50MΩ in a coupling capacitor is high enough to be innocuous but, as Fig. 2 shows, it is capable of causing the grid voltage of a following valve to be raised by no less than 1.5 volts. In many instances, this could cause quite significant distortion.

If the leakage resistance drops to 20MΩ, which most of us would look upon as being the highest resistance we can usefully check with general run-of-the-mill servicing gear, the direct voltage developed across the 470kΩ grid resistor would be no less than 3.5 volts, working from the circuit of Fig. 2.

A servicing difficulty when looking for a leaky a.f. coupling capacitor is that the leakage current is very low. For example, a capacitor with a 50MΩ leak in a circuit similar to that of Fig. 1 passes a current of some 3μA only. This can bring an a.f. voltage amplifier well into distortion conditions but it would hardly move the needle of a testmeter switched to a low volts range and connected across the 470kΩ grid resistor.

Fortunately, there is a dodge which can pin-point the faulty a.f. coupling capacitor. This consists of a simple short-circuit test, and it is shown in Fig. 3. Switch on the amplifier, turn up its volume and run it with no signal input. If all is well there should be the normal background hiss from the loudspeaker. Then, with a short piece of wire, short-circuit the grid resistor following any suspect a.f. coupling capa-

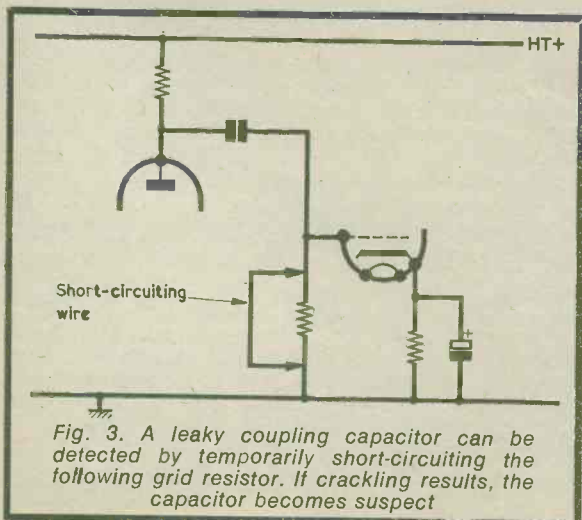

AUGUST 1971

## NEW HANDIPAK

# PANEL SIGNS

### IDEAL FOR WORKSHOP USE

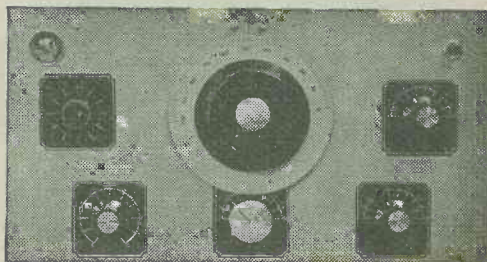

- Easy to fix
- Permanent and durable
- Stapled in booklet form
- Designed to hang above workbench
- Pocket for loose cuttings
- Professional finish

- ★ Set 3 Wording—WHITE
- ★ Set 4 Wording—BLACK
- ★ Set 5 DIALS—clear background
- ★ Set 6 DIALS—black background

The Perfect Transfer for  
the Home Constructor

Each Set contains Six Sheets

# 25p per set

(postage 3p)

To Data Publications Ltd.  
57 Malda Vale, London, W.9

Please supply:

.....Set 3 .....Set 4 .....Set 5 .....Set 6

I enclose cheque/crossed postal order for.....

Name.....

Address.....

RC

BLOCK LETTERS PLEASE

citor. As is to be expected, the hiss from the loudspeaker will either disappear or diminish, according to the position of the associated valve along the amplifier chain. Should this be all that happens, the coupling capacitor preceding the grid resistor is almost certain to be perfectly serviceable. If, on the other hand, the reduction or disappearance of hiss is accompanied by a *crackle* when the short-circuiting wire is applied and by another *crackle* when the wire is removed, then the preceding coupling capacitor is probably leaky and is thereby causing the appearance of a direct voltage across the grid resistor. The crackle is given because the short-circuiting wire has abruptly changed the direct voltage on the grid following the coupling capacitor. If the coupling capacitor had had 'infinite' leakage resistance, the direct voltage across the grid resistor would have been zero both before and after application of the short-circuit.

When applying the short-circuiting wire, connect the earthy end first and then apply the other end to the grid. Otherwise, grid hum will tend to mask the existence of the crackle. The wire can be made up in permanent form as a short length of single flex with insulated test prods at both ends. Remember that the earthy end of the grid resistor of an a.f. amplifier valve does not always connect direct to chassis; in some amplifier circuits it may connect to a point slightly above or below chassis potential. The short-circuit *must* be applied across the grid resistor itself, regardless of the point at which its earthy end terminates. If in doubt, apply the short-circuiting prods directly across the grid resistor itself.

In a few instances, internal leakage in the valve can cause the crackle to appear when the short circuit is applied, whereupon the coupling capacitor can be finally isolated as being faulty or not by re-checking with a replacement valve plugged in. A false crackle may be given if the valve in question has 'grid current bias', in which mode of operation the cathode is connected directly to chassis instead of via the usual cathode bias resistor and bypass capacitor. Fortunately, grid current bias is not frequently employed with valves whose input coupling capacitor connects to a preceding anode circuit.

#### SPECIAL CASE

A special case which can point directly to a leaky coupling capacitor is possible in the circuit of Fig. 4. Here, the coupling capacitor connects to a volume control. If the capacitor exhibits leakage resistance the grid of the valve will be biased more and more positive as the slider of the control moves towards the maximum volume end of the track. In consequence, distortion will increase as volume is increased. The leakage can be detected by the short-circuit test just described, the short-circuit being applied across the track of the control with the slider

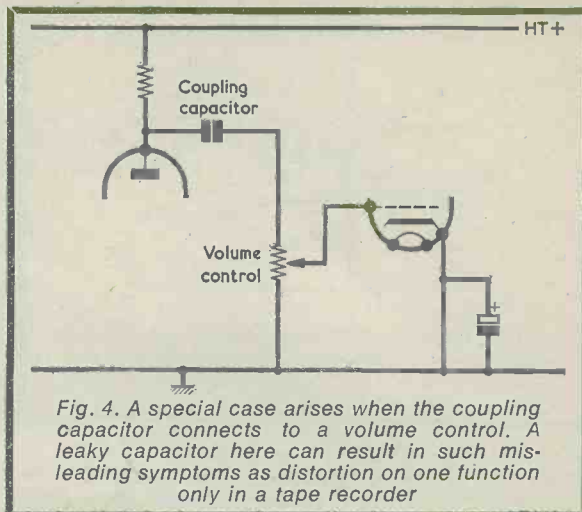

Fig. 4. A special case arises when the coupling capacitor connects to a volume control. A leaky capacitor here can result in such misleading symptoms as distortion on one function only in a tape recorder

at its full volume position.

Alternatively, a leaky coupling capacitor in the circuit of Fig. 4 may not cause sufficient direct voltage to appear across the volume control track to introduce significant distortion, but it may cause the control to be 'crackly' as it is operated. This is because the slider of the control tends to 'hop' in tiny discrete steps from one resistance value to the next as it travels along the track, instead of providing a completely smooth change of resistance. The effect does not give audible results with signal voltages unless the control track is really worn but if, because of a leaky coupling capacitor, a small direct voltage is present across the track the small changes in direct voltage applied to the valve grid will produce the 'crackly' operation. Once again, the trouble can be isolated by the short-circuit test.

An interesting example is given when the circuit of Fig. 4 appears in the common record-playback amplifier of a tape recorder, and in which the potentiometer acts as record level control in the first function and as playback volume control in the second. It often happens that the potentiometer slider is advanced much higher for one function than for the other, a typical instance being given when it is turned to a very high position whilst recording weak sounds with a microphone. If the coupling capacitor is leaky, the result can be that distortion is only evident on the function which requires the slider of the potentiometer to be much nearer the non-earthly end of its track, whereupon a much higher positive voltage is applied to the grid of the following valve. The cure is obvious, and the fault will be traceable with the aid of the short-circuit test when the recorder is switched to playback. ■

### "NON-OVERLOAD POWER SUPPLY"

Our attention has been drawn to the fact that a number of articles describing power supplies and employing the same or similar principles to those in our article under the above title (published in the May 1971 issue) have appeared in our Australian contemporary "Electronics Australia". Since these articles preceded the references given in our May, 1971 article, we list them here to provide full information. All appeared in "Electronics Australia" (previously "Radio, Television and Hobbies"). Jamieson Rowe, "A Regulated Nine-Volt Power Supply", February 1963; J. Davidson and Jamieson Rowe, "Power Supplies for Transistors and Portables", November 1964; Ian Pogson, "A Fully Protected Variable D.C. Supply for Transistors", April, 1966; Jamieson Rowe, "A Simple Low-Cost Transistor Power Supply", January 1969; and Leo Simpson, "A Shunt-Regulated Power Supply", March, 1970.

In Fig. 2 on page 613 of the May, 1971, issue, the collector of the ACY19 should connect to the negative supply rail.





# Latin American Quest

## (5) BOLIVIA BRAZIL

### FRENCH GUIANA PERU

CONTINUING THE LA QUEST, WHICH LAST MONTH covered Colombia, Ecuador, Guyana and Venezuela, the next country on the list is Bolivia.

#### BOLIVIA - AN OUTLINE

This country has an area of 412,772 square miles and a population of about 4,000,000. It is one of the two inland countries on the continent. The legal capital is Sucre but the political and commercial centre is La Paz. Sucre is named after the victor of Ayacucho (1824) during the war against Spain.

The East of the country is tropical, the North is of rain forests drained by the rivers of the Amazon basin, the South merges into the Chaco and the West section is Andean, one cordillera (mountain ridge) traces the border with Chile. In the S.West is a large salt plain whilst in the N.West lies the basin of Lake Titicaca. On the Altiplano (high windswept plateau) between mountain ranges and in the valleys lie the chief centres of population. Important towns are Potosi and Oruro, the cities Cochabamba and Tarija.

There are, of course, other Brazilian stations than those listed in Table VI but in the main they are

difficult to receive in this country. Many of these stations occupy channels on which other, more powerful, S.American transmitters are operating. In the main, Bolivian stations are not often reported by SWL's in the UK.

#### Bolivia - Short Waves

Bolivia is four hours behind GMT and the language is Spanish. Most of the short wave stations operate on the l.f. bands from 6MHz down to 3.2MHz and are of relatively low power - in the main 1kW.

The most consistent signal from Bolivia over the past few years, in terms of reception here in the U.K., has been that of CP38 La Paz on 5045kHz (5kW). This has probably been occasioned by the fact that 'Radio Altiplano' has a 24 hours schedule on a channel occupied by three 1kW Brazilian stations and a further 1kW transmitter on remote Cook Islands in the Pacific. From 0430GMT onwards, CP38, in practice, has a clear channel.

Table VI lists some of the Bolivian stations reported in the U.K. SWL press during the past season.

TABLE VI

kHz	kW	Station	Schedule GMT
4825	1	CP70 Santa Cruz, "Radio Grigota" ... ..	1000-0300
4845	5	CP72 La Paz, "Radio Fides" ... ..	1030-0300
4875	10	CP75 La Paz, "La Cruz del Sur" ... ..	1000-1800 2200-0300
5045	5	CP38 La Paz, "Radio Altiplano" ... ..	24 hours

#### BRAZIL - AN OUTLINE

The Republic of Brazil has an area of 3,287,842 square miles and a population of about 85,000,000. Situated in East South America, the full name of the country is United States of Brazil. The capital city is Brasilia.

Brazil is the largest country in S.America, occupying nearly half of the continent. Bordered by Venezuela, Guyana, Surinam and French Guiana on the North; Colombia, Peru and Bolivia on the West; the Atlantic Ocean on the East and Paraguay and Uruguay in the South. Populated coastal areas contrast sharply with the huge undeveloped interior, the new capital Brasilia being built in the interior to hasten development.

The principal cities of Brazil are the ports of Recife, Fortaleza, Maceio, Salvador, Natal, and the former capital Rio de Janeiro. The inland city of Belo Horizonte is a thriving commercial centre. Curitiba, Belem and Porto Alegre are also important centres.

Although others had visited the coast earlier, the Portuguese adventurer Cabral is usually considered to be the 'discoverer' (1500). Portuguese settlement slowly took place, that at Sao Vicente in Sao Paulo state being the first permanent site.

After a chequered start, which included driving French Huguenots from Rio de Janeiro harbour (1567) and driving the Dutch from the Northeast (1654), Brazil welcomed King John VI of Portugal

who fled from that country upon the Napoleonic invasion and made Rio de Janeiro the capital of the Portuguese Empire. After Waterloo, the King returned to Portugal, leaving his son as Regent in Brazil. In 1822 the Prince proclaimed Brazil as independent and became Emperor Pedro I, later abdicating in favour of his son, Pedro II. Since that period (1831-1889) Brazil, with immigration, coffee and wild-rubber, has become a modern nation and was proclaimed a republic in 1889.

#### Brazil - Short Waves

Brazil is so large that differing areas have times that are from three to five hours behind GMT. The main language is, as might be expected from its history, Portuguese.

The country is easy to log on the short waves and the list of stations currently operating on these frequencies is large indeed. On the LF broadcast bands, with which we are mostly concerned in this series, there are several Brazilian stations that put relatively

consistent signals into the UK. Apart from the Venezuelan stations, who top the poll, it is the Brazilian transmitters that are most often reported by SWL's, the country operating well over one hundred short wave transmitters.

Brazil has another claim to fame on the short waves. Unlike other Latin American countries, it has a large number of stations operating on the higher frequency bands (6MHz and above). Often, if conditions are right, the 25 and 31 metre bands will provide the listener with every chance of logging many Brazilian stations.

Table VII presents those stations most commonly heard in this country.

It should be mentioned here that, as with most other Latin American transmitters, the Brazilian schedules are often extended beyond the listed time of sign-off, usually owing to a public holiday or festival (often the same thing in LA) or a commentary on 'futebol' - about which they are apt to be extremely enthusiastic!

TABLE VII

<i>kHz</i>	<i>kW</i>	<i>Station</i>	<i>Schedule GMT</i>
4865	2	PRC5 Belem, "Radio Clube do Para" ... ..	0900-0300
4895	5	PRF6 Manaus, "Radio Bare" ... ..	0900-1100
			2200-0300
4905	5	ZYZ20 Rio de Janeiro, "Radio Relogio" ... ..	24 hours
4975	5	ZYV9 Sao Luiz, "Radio Timbira" ... ..	1200-0300
4995	5	ZYX2 Goiania, "Radio Brazil Central" ... ..	0800-0400
5035	1	ZYW22 Goiania, "Radio Anhanguera" ... ..	0900-0400
6015	10	PRA8 Recife, "Radio Clube de Pernambuco" ... ..	0900-0300
6055	7.5	PRB21 Sao Paulo, "Radio Panamericana" ... ..	2100-0300
11865	7.5	PRA8 Recife, "Radio Clube de Pernambuco" ... ..	0900-0300

#### FRENCH GUIANA - AN OUTLINE

Guiana is a region of North-East South America roughly bounded by the Orinoco basin, the Casiquiare channel (which connects the Orinoco with the Rio Negro), the Amazon basin and the Atlantic. This narrow coastal region is very rainy and hot, the vast unexplored, unexploited, interior including the Guiana Highlands as well as the large savannas and vast rain forests. The region includes part of South Eastern Venezuela, part of North Brazil and the three Guianas. Westernmost is the former British Guiana (now Guyana); central is the former Dutch Guiana (now Surinam) and Easternmost is French Guiana.

French Guiana has an area of 23,000 square miles and a population of 35,000 and is a department of overseas France, comprising the colony proper and

the interior territory of Inini. The capital is at Cayenne. Devil's Island, the notorious penal colony (until 1946), is a part of French Guiana.

#### French Guiana - Short Waves

French Guiana is three hours behind GMT and the programme language is French. There are only two stations on the short waves, both with a power of 4kW. The frequencies are - 3385kHz and 6170. The evening schedule of the former station is from 2030 to 0100 (Saturdays till 0200); the latter transmitter closes down at 2030 and is unlikely to be heard in the UK.

Cayenne is reported from time to time on the 3385kHz channel by listeners in the UK, but the occasions are few and far between. Not an easy country to log by any means.

#### PERU - AN OUTLINE

Peru has an area of 496,093 square miles, a population of around 11,000,000 and is situated in West South America. The population is 50% Indian, the remainder being made up of oriental, European and mestizo (mixed Spanish/Indian).

Peru is bounded on the West by the Pacific Ocean, on the North West by Ecuador, on the North by Colombia, on the East by Brazil and part of Bolivia and in the South by Chile.

The country is divided into two by two ranges of the Andes with high altiplano lying between, a barren and cold region except that lying around Lake Titicaca. The Western range has the high volcanoes Huascaran and El Misti. In the East are the rain forests of the Amazon basin, being drained by the Ucayali and Maranon rivers. The undoubted great resources of Peru are largely unexploited.

The capital of Peru is Lima, the chief port is Callao, the old Inca capital being Cuzco situated on



the altiplano. Along the Pacific coast there is about 1,400 miles of desert intensively irrigated and devoted to agriculture. Off the coast lie the Lobos and Chíncha islands which yield guano fertiliser. Transportation in Peru is very difficult by virtue of the Andean ranges and the primitive road system.

The last Incan ruler, Atahualpa, was treacherously executed by the small band of Spanish adventurers under Francisco Pizarro, the conquest beginning in 1532. At the battles of Junin and Ayacucho in 1824 the Spanish were defeated and Peru became independent.

#### Peru - Short Waves

Peru is five hours behind GMT and the main programme language is Spanish, but many of the Peruvian stations radiate programmes in which Quechua, the main language of the large Indian population who reside on the altiplano, is largely featured.

Of all the countries of South America, Peru is the most difficult to receive and in many ways the most appealing. Most of the short wave stations have powers of 1kW or less and none of them are intended for listeners outside the country. Low powers and omni-directional aerial systems make Peru a rare catch indeed on the short wave ranges - particularly on the low frequency bands.

The three zones of Peru, the Amazon basin, the Andes and the coastal region have stations whose programmes differ from each other. In the Andes the stations have many hours of Spanish language lessons for the illiterate Indian population, still largely separated from the main stream of Peruvian life. The object of these stations is to provide the Indian with a basic education. To the writer's mind, these are the most appealing transmissions emanating from Latin America for it is from these stations that the haunting, plaintive melodies of the altiplano Indians can be heard. Rendered on a flute and guitar, such melodies reflect the sad, hard life of the true descendants of the Incas.

In the Amazon region, the broadcast language is mainly Spanish and the music is more in line with

that of S.America generally.

On the coast, in which region lies the capital Lima, are most of the stations likely to be received in the UK, Cuzco or Iquitos being well known places to LA specialists. The music of the coast is much like that of S.America generally.

The Andean stations, those most favoured by the dyed-in-the-wool DX'er, are the most difficult to receive and identify not only by virtue of their low powers but also for the reason that they often broadcast many hours of 'altiplano music' with few station identifications.

The Indian population is not only illiterate but also very poor and in these circumstances it is not surprising that commercially-based stations find programme sponsors few and far between. To remain viable, these stations encourage the local populace to bring along a small payment and specify a favourite record to be played over the air at a given time. In general, such requests signify a family event such as a wedding, birthday or other notable happening. These transmissions form the well known 'petitions' programmes which often last for hours and hours.

Much more could be written about Peruvian stations but in this present series space is not available for a more lengthy discussion. In Table VIII are listed those stations most often received in the UK on the low frequency bands. For the beginner, we would recommend Radio Cuzco on 6250kHz (1kW) from around 0300 to 0500GMT. The channel is a clear one and if conditions permit, station identifications will be heard at every quarter hour and, at times, even more frequently.

As may be gathered from earlier remarks, Peru is not an easy LA country to receive here in the UK. In fact, it is the most difficult of them all in terms of low frequency bands reception - which is what this series is all about. The low powers of the transmitters involved and the high Andean ranges together with the Quechua language, often interspersed with Spanish, are not conducive to easy 'catches'. The most favourable time period for UK listeners is from around 0300 to 0500.

TABLE VIII

<i>kHz</i>	<i>kW</i>	<i>Station</i>	<i>Schedule GMT</i>
3250	1	O BX4U Lima, "Radio America" ...	1300-0500
3330	1	O AX1M Piura, "Radio Progreso" ...	1200-0500
3350	1	O AX5E Ica, "Radio Independencia" ...	1200-0500
3380	1	O AX1O Chiclayo, "Radio Chiclayo" ...	1200-0500
4815	1	O AX8X Iquitos, "Radio Amazonas" ...	1100-0500
5058	1	O AZ4A Tarma, "Radio Tarma" ...	1200-0500
5182	1	O AX8F Iquitos, "Radio Atlantida" ...	1200-0500
6250	1	O AX7A Cuzco, "Radio Cuzco" ...	1200-0500

Next month the final article in the present series will deal with Argentina, Chile, Paraguay and Uruguay.

(To be concluded)

## PARIS ELECTRONIC EXHIBITIONS - 1972

In 1972 three great international exhibitions will be organised by the "Société pour la Diffusion des Sciences et des Arts (S.D.S.A.) under the patronage of the "Fédération Nationale des Industries Electroniques" (F.N.I.E.):

- International Audio Festival From 9th to 14th March, 1972.
- International Exhibition of Electronic Components From 7th to 13th April, 1972.
- International Show, Radio-Television-Audio Equipment From 31st May to 11 June, 1972.

# In your workshop



As is their custom in August, Dick and Smithy take a day off from the Workshop. This time they sample the offerings of a restaurant in a nearby country town, but they still find time to examine the basic principles of forward a.g.c. systems in hybrid TV receivers

"LET ME," SAID DICK, STRUGGLING to reduce the tone of incredulity in his voice, "get this quite clear. You are going to pay for this lunch?"

"I am," confirmed Smithy cheerfully. "Apart from demonstrating any innate generosity, this gesture also helps in the maintenance of good Management-Staff relations."

"Blimey," remarked Dick, impressed. "Well then, thank you, Smithy."

"Don't mention it, my boy. Here, take a look at the menu."

Smithy handed one of the two menus on the restaurant table to his assistant and then looked around him. As was their habit in August, the pair had decided to spend a day away from the Workshop. They had caught a bus to a nearby country town and, after a little exploring, had decided to have lunch in the small restaurant in which they now sat. There was ample evidence here of the carefree holiday atmosphere of Summer. People who patently had all the time in the world to spare strolled casually in and out, or dealt leisurely with the meals that lay in front of them.

The restaurant itself was rather more select than its outward appearance had indicated. Smithy noted with satisfaction that its menu was, nevertheless, stolidly English in character.

"You go first, Dick," urged Smithy.

Dick looked down at his menu. "Can I," he asked, "have fillet steak?"

"You may," replied Smithy benevolently.

"With chips and peas?"

"Of course."

"Then that's what I'll have."

"Excellent," pronounced Smithy enthusiastically. "And I'll have the same too, please."

"Right, sir," said the waitress.

She looked at Smithy thoughtfully for a moment then moved away, to return with a basket of rolls which she offered to the two. They selected one each, after which she walked smartly towards the nether regions of the restaurant.

"Hey, take it easy," remonstrated Dick, after the sprightly tight-clad form had finally disappeared. "A man of your age shouldn't excite himself too much, you know. Blimey, Smithy, your eyes are standing out like organ-stops."

"Fiddlesticks," retorted Smithy, regretfully taking his gaze away from the closed door through which the waitress had finally passed and directing it on the homely features of his assistant. "And I'm not as old and decrepit as you seem to think, either. There's plenty of forward bias in my thinking still."

Dick gathered breath to reply to this pronouncement, then paused as a thought struck him.

"It's funny you should say that," he remarked. "I've been puzzling over something to do with forward bias for quite some while. Hang on a minute."

He felt inside his shirt pocket, then produced a sheet of paper. As he unfolded it, this became revealed as a circuit diagram taken from a TV service manual.

An exasperated expression creased Smithy's face.

"This just about caps everything," he growled irately. "It's bad enough my having to answer your continual technical questions when we're at

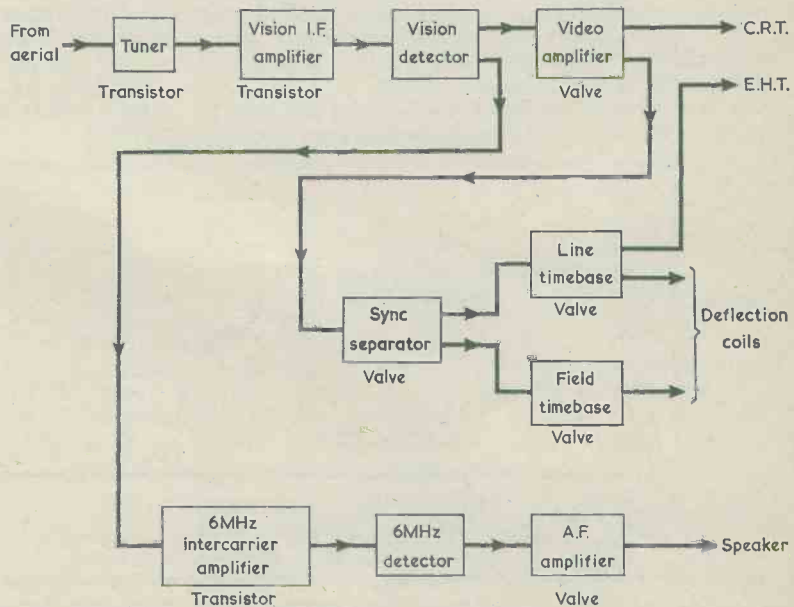

Fig. 1. Single-standard hybrid television receivers tend to distribute transistor and valve circuits in the manner shown in this block diagram. Some receivers may use one or more transistors in the video amplifier or sync sections, valves still being employed for a.f., line and field output stages

## SHOP TALK

A trim, briefly mini-skirted waitress materialised at their table, notepad in hand.

"Yes, gentlemen?"



work; but it's really too much expecting me to put up with them as well when I'm taking a day off."

"There are only one or two minor points that are worrying me," wheedled Dick. "You could clear them up in no time at all."

"Oh, all right then," said Smithy irritably, as he took the circuit from Dick and briefly examined it. "For a start, it's obvious enough that this is the circuit of a 625 line single-standard hybrid monochrome TV. You can see at a glance that it's single-standard because there are no 405-625 line system switches anywhere in the circuit. Hybrid sets are those which have both transistors and valves, and this one is pretty typical of the sort of thing you get. These sets usually have the tuner, the i.f. amplifier and the 6MHz intercarrier sound amplifier transistorised, with valves in the remainder, or nearly all the remainder, of the set." (Fig. 1).

"That bit's clear enough," said Dick. "It's your reference just now to 'forward bias' that reminded me of the question I wanted to ask you. Will this set have forward a.g.c.?"

"Very probably," replied Smithy carelessly. "Forward a.g.c. is common practice with single-standard hybrid TV receivers. Now that you've got me started, let's see, as a matter of interest, how the transistor stages are powered."

He examined part of the circuit closely, then chuckled.

"I like the cunning way in which set designers conjure up the low supply voltage needed for the transistor stages in these hybrid models. For instance, this set uses a method which, you may recall, we discussed some months ago. The transistor power is obtained from a winding on the line output transformer." (Fig. 2(a)).

"I remember that," replied Dick promptly. "The winding feeds a rectifier and smoothing circuit, doesn't it?"

"That's right," confirmed Smithy. "There's an alternative idea used in other sets which is just as neat."

Smithy took a pen and sketched a circuit in the margin of Dick's service sheet. (Fig. 2(b)).

"With this second method," he continued, "the valve heater chain is supplied via a half-wave silicon rectifier which, by itself, considerably reduces the value of the series dropping resistance that's required. A low value resistor is then inserted at the chassis end of the heater chain with a reservoir capacitor across it, this being followed by a smoothing resistor and another electrolytic. The transistor stages then take their power from the second electrolytic. See?"

"That's crafty," remarked Dick. "Are there any other ways of ob-

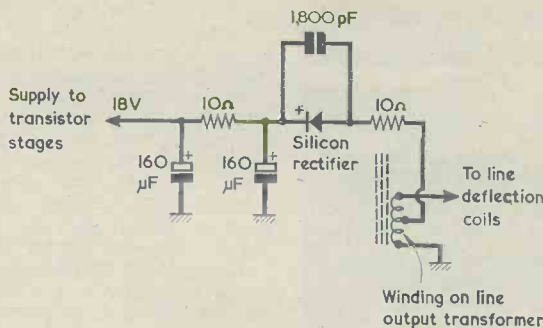

(a)

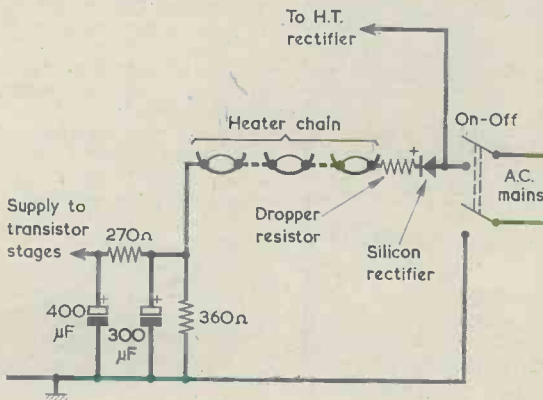

(b)

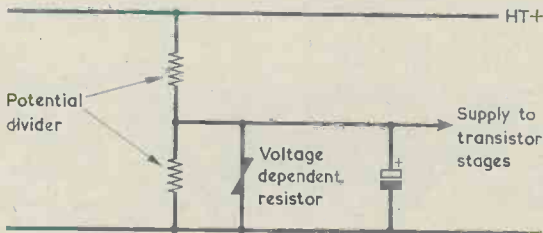

(c)

Fig. 2(a). In some receivers the low-voltage transistor supply is obtained from a winding on the line output transformer. (This circuit previously appeared in 'In Your Workshop' in the March 1971 issue)

(b). Another method of obtaining the transistor supply in a hybrid receiver. Component values are representative

(c). In some sets the transistor supply is obtained from the main h.t. line by way of a potential divider

taining the supply for the transistor stages?"

"There's a third method," replied Smithy. "This is rather more mundane, but it still does the job very effectively. It consists of taking the transistor supply from the main h.t. line of the set by way of a fixed potential divider given by two or more resistors in series. Since the h.t. current drawn by the potential divider and the transistors is of the

same order as that which would have been drawn by the valves they replace, this arrangement means that the h.t. supply circuit and components can be pretty well the same as those in a fully valved set. The voltage across the bottom resistor in the potential divider is stabilized by a v.d.r., or voltage dependent resistor." (Fig. 2(c)).

"I'd have thought," commented Dick, "that a zener diode would

## Your Local Supplier

LONDON

Established 1910

### H. L. SMITH & CO. LTD.

Comprehensive stocks of  
components by  
all leading makers

287-9 EDGWARE ROAD  
LONDON W.2

Tel: 01-723 5891

### THE MODERN BOOK CO.

Largest selection of English &  
American radio and technical  
books in the country.

19-21 PRAED STREET,  
LONDON, W2 1NP

Tel: 01-723 4185/2926

### ST. HELEN'S RADIO

Hi-Fi Equipment  
Tape Recorders  
Radio Receivers  
Television

SPECIALISTS IN RADIO  
& ELECTRONIC TEXTBOOKS

ST. HELEN'S GARDENS  
LONDON, W.10

Tel: 01-969 3657

BEDFORDSHIRE

### SURPLECTRONICS

THE SELF-SERVICE  
COMPONENTS SHOP  
THAT SAVES YOU MONEY

CHOOSE FROM 1200  
ASSORTED BOXES  
AT YOUR LEISURE

9 a.m. to 5.30 p.m. every day.  
Closed all day Wednesday

WE ARE IN LUTON  
AT 216 LEAGRAVE ROAD  
LUTON, BEDS

have been the best stabilizing device to use there."

"Perhaps so," stated Smithy, "but, nevertheless, it's usual to employ a v.d.r. instead. A voltage dependent resistor has a voltage-current characteristic which is rather similar to that of a zener diode, since its effective resistance reduces rapidly as the voltage across it increases. The change in resistance is by no means as abrupt as you have with a zener diode, but it is still good enough when a high degree of stabilizing is not required. TV set manufacturers use v.d.r.'s much more frequently than zener diodes for low voltage stabilization." (Fig. 3(a) and (b)).

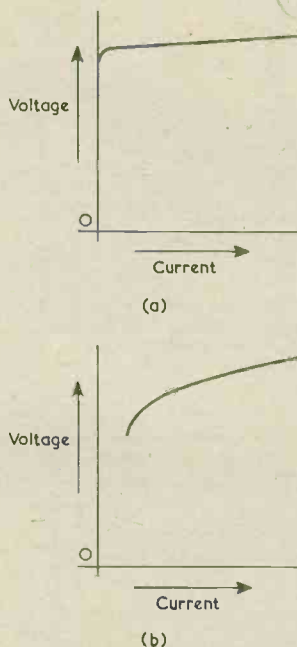

Fig. 3. Voltage-current characteristics of (a) the zener diode and (b) the voltage dependent resistor

#### FORWARD A.G.C.

Smithy glanced up as he suddenly realised that a black-coated figure was hovering beside his chair.

"Some wine," asked the figure, "with your meal, sir?"

Smithy looked back at the wine-waiter uncertainly.

"Er, what have you got?"

"The wine list is on the back of the menu, sir."

Smithy picked up the menu, turned it over and looked at the list with an air of total incomprehension.

"A spot of *Nuit St. Georges* might be rather good," remarked Dick, who was studying the list at the back of his own menu.

Smithy stared at his assistant.

"But I think," continued Dick, absorbed in the wine list, "that a warm day like today calls for something with a little more zest. How about a *Liebfraumilch*, Smithy?"

"I should think," stammered Smithy, "that that would be very nice."

"An excellent choice, sir," commented the wine-waiter. "A bottle?"

"We'd better have a half-bottle, Smithy," said Dick patronisingly, "seeing that you're not used to it."

"What d'you mean, I'm not used to it," snorted Smithy. "We'll darned well have a full bottle."

The waiter inclined his body slightly, then drifted away. Smithy threw a dubious glance at his assistant.

"I didn't know you were such an expert on wine," he remarked suspiciously.

"Brought up on it, dear boy," replied Dick airily. "Anyway, let's get back to this forward a.g.c. business."

"Ah yes," said Smithy, forgetting the fathomless mysteries of the wine list for the moment. "Well now, we discussed forward a.g.c. recently at the same time as we talked about that transistor power supply which is taken from the line output transformer. I told you then that there are two ways of applying a.g.c. to a transistor. There's 'reverse a.g.c.', with which transistor gain is lowered by reducing the base bias current, and that's the sort of a.g.c. you get in transistor portable radios. And there's 'forward a.g.c.', with which the gain of the transistor is lowered by increasing base bias current. The increased base bias current reduces the impedance in the base-emitter junction of the transistor. The base material from the base terminal to the actual junction can be looked upon as a resistor, with the result that reducing the junction impedance means that less signal voltage appears across that junction."

"I remember all that," said Dick a little impatiently. "I remember also that the advantage of forward a.g.c. is that it enables the transistor to pass a high collector current when it's biased for low gain, with the result that it cannot be overloaded by a strong signal, as can a transistor that is heavily biased back in a reverse a.g.c. circuit."

"Then," remarked Smithy, "you've got pretty well the whole picture. The fact that the transistor cannot be overloaded when it's biased well forward means that it does not introduce cross-modulation effects. Referring back to our previous discussion, the final point we made then was that forward a.g.c. may only be used with transistors which are specially designed for it."

"Which brings me to the question

THE RADIO CONSTRUCTOR



I was going to ask you just now," said Dick. "Why do they call it forward a.g.c.? 'Forward' seems to be a funny name for a system that works dead opposite to all the a.g.c. systems that have been used in the past."

"The name bit is quite easy," replied Smithy. "To start off with, think of a diode having a p.n. junction. If you connect a battery or cell to it with the positive terminal going to the n section and the negative terminal going to the p section, no current flows and the junction is said to be reverse-biased. If, on the other hand, you connect the positive battery terminal to the p section and the negative battery terminal to the n section, current flows through the junction and it's described as forward-biased." (Figs. 4(a) and (b)).

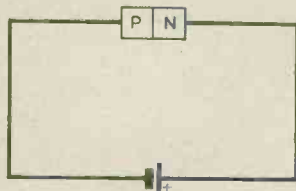

Reverse bias

(a)

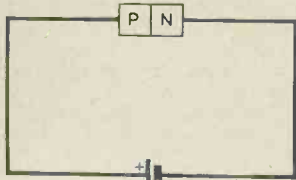

Forward bias

(b)

Fig. 4(a). A cell connected to apply reverse bias to a p.n. junction  
(b). Here, forward bias is applied by the cell

"I think I can see what you're getting at here," remarked Dick. "Go on, Smithy."

"Right," said Smithy. "Now, in both reverse and forward a.g.c. systems we vary the bias current in the base-emitter junction of the controlled transistor. With reverse a.g.c. we reduce gain by going in the reverse bias direction whilst, with forward a.g.c., we reduce gain by increasing the forward bias. Simple, isn't it?"

"Blimey, so it is," responded Dick. "The whole thing makes perfect sense if you think in terms of reverse and forward bias at the base-emitter junction. Here, watch it!"

But Dick's admonition was unheeded. The waitress had reappeared and was now approaching their table, whereupon Smithy's eyes once more took up their secondary function as organ voice controls. The girl smiled at the Serviceman as she placed a jar on the table.

"I thought," she said pertly, "that you might like French mustard with your steak."

"Very thoughtful of you, my dear," replied Smithy, returning the smile. "One does get so tired of the native condiments, doesn't one?"

"Indeed, sir."

She lingered a moment and continued to smile at the Serviceman.

"I'll bring your steak in a moment."

She left, and once more Smithy gazed fondly at her retreating figure.

"Native condiments?" exploded Dick derisively. "Corluvaduk, mate, you don't know the difference between French mustard and brown chop sauce!"

"Of course I do," retorted Smithy. "The trouble with you, Dick, is that you've got jealous just because she fancies me. What you youngsters don't realise is that modern girls go for the more mature and manly type of person, such as me."

The Serviceman airily polished his fingernails on his lapel.

"It's the greying hairs at the temples," he continued. "That's what gets them."

Dick stared unbelievably at the Serviceman.

"I've heard of self-deception," he remarked, "but this is plain ridiculous. I'll agree that the few wisps of hair that are left at your temples could be greying if, that is, there were enough of them to enable any definite colour to be established. But over the rest of your bonce you're as bald as a bat!"

However, Smithy was not to be moved from the state of beatitude in which the waitress had left him.

"That," he remarked mildly, "is what is, I believed, called the Yul Brynner look. Hallo, who's this?"

"It's the wine-waiter with your *Liebfraumilch*."

"So it is."

The waiter sidled up to the table, put two glasses on it and showed Smithy the wine bottle.

"Very good, my man," said Smithy imperiously. "It's still got the cork in it, though."

"I am," remarked the waiter a little coldly, "about to remove it, sir."

The waiter inserted a corkscrew and, with a flourish, pulled out the cork. He then leaned over and poured a little of the contents of the bottle into the glass in front of Smithy. The Serviceman looked at the glass, with its quarter-inch level

## Your Local Supplier

HAMPSHIRE

### BOURNEMOUTH

LARGEST HI-FI AND RADIO COMPONENT STORE IN THE SOUTH

FORRESTERS NATIONAL RADIO SUPPLIES LTD.

70-72 Holdenhurst Road

Bournemouth

Telephone 25232

SUSSEX

### E. JEFFRIES

For your new television set  
tape recorder, transistor radio  
and hi-fi equipment

PHILIPS, ULTRA, INVICTA,  
DANSETTE, MASTERADIO, PERDIO,  
MARCONI, PHILCO, FIDELITY

6A Albert Parade  
Victoria Drive,  
EASTBOURNE SUSSEX

YORKSHIRE

### WILSIC ELECTRONICS LTD.

Your local supplier for  
EAGLE PRODUCTS  
CYBERNAT MOTORING AIDS  
WILSIC HI-FI, MUSICAL  
EQUIPMENT, KITS AND  
COMPONENTS

Send 15p (3/-) for our Catalogue  
Eagle Products Catalogue 20p (4/-)

6 COPLEY ROAD  
DONCASTER

EIRE

### PEATS for PARTS

ELECTRONIC COMPONENTS  
RADIO & TELEVISION

For the convenience of Irish  
enthusiasts we supply:

The Radio Constructor  
Data Books and  
Panel-Signs Transfers

Also a postal service

Wm. B. PEAT & Co. Ltd.  
28 PARNELL STREET  
DUBLIN 1

of wine, then turned back to the waiter.

"Is this," he asked querulously, "all I get?"

"You're supposed," hissed Dick from the opposite side of the table, "to sip it."

"Sip it? Whatever for?"

"To see if it's all right, of course."

"To see if it's all right?" repeated Smithy incredulously. "Stap me, don't they know if it's all right, then? This is a right turn-up for the book I must say, flogging you wine which you've got to check for yourself."

With the gesture of one who passed mere desperation several miles back, Dick quickly reached over, picked up Smithy's glass and sipped its contents.

"This will be fine," he told the wine-waiter, whereupon that worthy proceeded to fill the two glasses and then left the bottle on the table. The waiter retired to the kitchen from which, some moments later, were heard shrieks of helpless laughter.

### A.G.C. CIRCUIT

"It's always the same when I go out with you," grumbled Dick bitterly. "You always show me up. It's a good thing I'm not known in this town, or I'd have left this restaurant ages ago."

"Don't be silly," retorted Smithy reprovingly. "You've still got the needle because of that waitress. Anyway, let's get back to this forward a.g.c. business."

"As you like," agreed Dick resignedly. "Anything to get my mind off our present situation. Well, I've been taking a look at the i.f. amplifier section in that circuit diagram I gave you. This is easy enough to follow, but I haven't been able to sort out the a.g.c. part yet."

Smithy once more turned his attention to the circuit, concentrating on the i.f. amplifier and its a.g.c. network.

"Ah yes," he remarked. "Well, this is pretty representative of hybrid TV i.f. amplifier and a.g.c. design. These hybrid sets have three

or four transistors in the i.f. strip and the usual thing is to apply the forward a.g.c. to the first transistor in the amplifier and to the r.f. amplifier transistor in the tuner. Let's concentrate first on the a.g.c. circuit going back to the i.f. amplifier transistor." (Fig. 5).

Smithy paused for a moment to collect his thoughts.

"When you're dealing with things like this," he resumed, "you must always keep signal polarities in mind. In this case, remember that the signal we're dealing with is a 625 line one which means that sync pulses have maximum transmitted amplitude. The i.f. amplifier in this particular receiver comprises a BF96 followed by two BF97's, the second BF97 feeding into the last i.f. transformer and then the vision detector. This detector is connected such that it allows negative half-cycles to pass on to its 3.3kΩ load resistor, and these are then fed to the grid of the video amplifier pentode. So, the signal at that grid has negative sync pulse tips correspond-

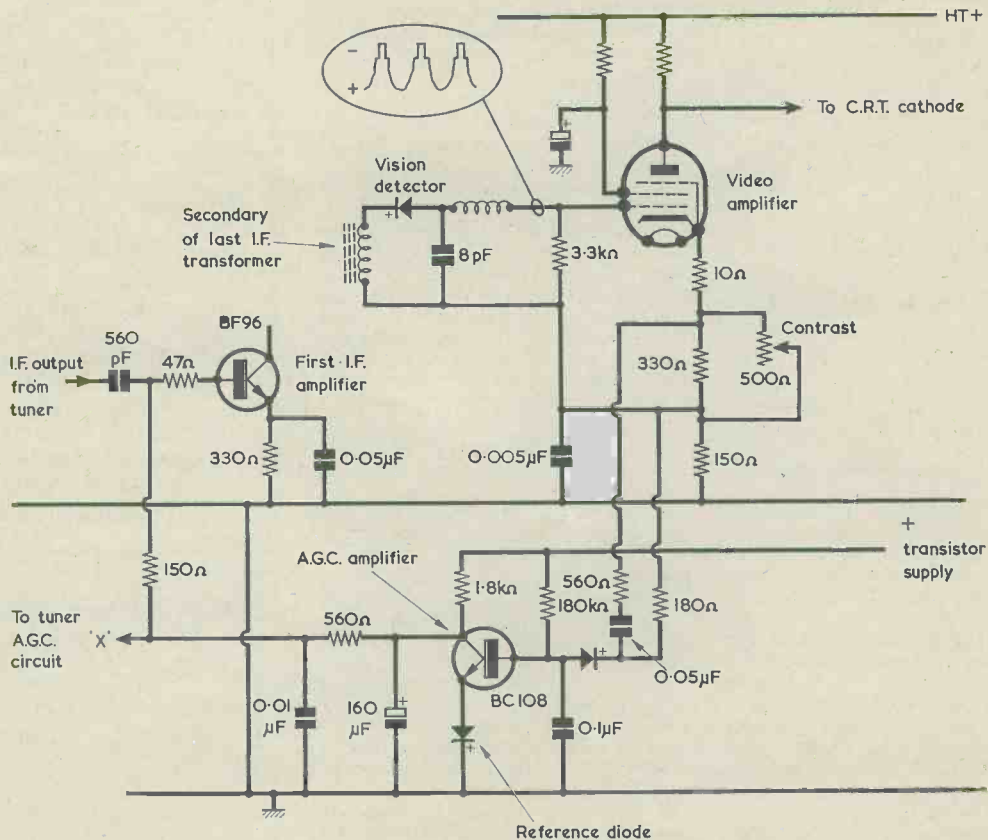

Fig. 5. Typical forward a.g.c. circuit, with a.g.c. amplifier between the video amplifier and first i.f. transistor. (This circuit and that of Fig. 6 are based on the appropriate stages in the G.E.C. 'Series One' range of receivers, with vision filters and 6MHz traps omitted for simplicity)



ing to maximum signal amplitude. Okay?"

"Yes," replied Dick. "Incidentally, there's another way of sorting out signal polarities which you told me about some time ago. What you said then was that, when in doubt with a monochrome TV circuit, always go to the cathode of the tube. The cathode always has sync pulses going positive and picture amplitude going negative. So, if we trace the cathode back to the video amplifier anode in the present circuit we can see that sync pulses at that anode go positive. Since the valve gives 180° signal polarity inversion, the sync pulses must go negative at the grid, which agrees with what you said just now."

"Very good," approved Smyth, "and I'm glad to see you remembered about tracing back from the tube cathode. In our present circuit the valve acts partly as a cathode follower, and a proportion of the video signal at its grid appears across the 330Ω resistor in its cathode circuit. There's no phase inversion from grid to cathode, so the signal at the upper end of this resistor has sync pulse tips which also go negative. And their amplitude corresponds, of course, with signal amplitude. These sync pulses are applied via the 560Ω and 0.05μF capacitor to the diode in the base circuit of the BC108, the latter being referred to as the 'a.g.c. amplifier'. The diode is connected such that it passes negative-going signals. D.C. continuity across the 0.05μF capacitor is maintained by the 180Ω, 330Ω and 560Ω resistors, which couple also to the 500Ω contrast control pot. Adjusting this pot sets up the signal amplitude applied to the diode and thereby allows the operating point of the a.g.c. system to be adjusted for the desired contrast setting. All right so far?"

"Yep," said Dick succinctly, "it's pretty fair sailing up to now."

"Good," replied Smyth. "It's not too hard from now on, either. We now have the situation where rectified negative sync pulses corresponding to signal amplitude are applied to the base of the BC108. These will be smoothed to a virtual d.c. by the 0.1μF capacitor between that base and chassis, with the result that the base potential goes negative as signal strength goes up. This means that the collector of the BC108 goes positive as signal strength increases. Now, the voltage on the collector of the BC108 is applied, via the following 560Ω, 150Ω and 47Ω resistors in series to the base of the first i.f. transistor. The result, then, is that as signal strength goes up, the forward bias in that base increases, giving us a forward a.g.c. system."

"What," asked Dick, "about that 160μF capacitor between the collec-

tor of the BC108 and chassis?"

"That gives you the a.g.c. time constant," said Smyth. "In company with the 1.8kΩ resistor coupling the BC108 collector to the positive supply line it offers a time constant of - let me see now - about quarter of a second when the voltage on the collector of the BC108 goes positive with increasing signal strength. The time constant when the collector goes negative depends upon how quickly the transistor discharges the capacitor."

#### TUNER A.G.C.

"Why, that's all there is to it, then," remarked Dick in a relieved tone of voice. "Understanding how the a.g.c. is applied to the first i.f. transistor is not at all difficult. What about the a.g.c. to the tuner, though? There seems to be another transistor involved there."

Dick pointed to a further transistor in the a.g.c. circuit. (Fig. 6).

"Ah yes," said Smyth, examining the section of the circuit indicated by Dick. "This is an a.g.c. delay circuit which ensures that no a.g.c. voltage is applied to the r.f. amplifier in the tuner until the received signal strength has exceeded a certain amplitude level."

"That's a common technique which was used in the valve days, isn't it?" broke in Dick. "The idea is to ensure that the r.f. amplifier in the tuner provides maximum gain for all signals up to a relatively advanced level."

"You've got it," confirmed Smyth. "These signals can then more readily override the noise generated in the mixer stage which immediately follows the r.f. amplifier. In the present circuit the voltage on the collector of the BC108 a.g.c. amplifier is passed, via the series 560Ω resistor, to the emitter of the p.n.p. BC158. The base of this transistor is held at a preset potential by the delay potentiometer to whose slider it connects. The pot is set up so that, at low signal strengths, the emitter is negative of the base and the transistor is cut off. Base current to the r.f. amplifier transistor in the tuner then flows from the junction of the 18kΩ and 2.2kΩ resistors connected across the supply rails through the 180Ω and 680Ω resistors in series. When, on receipt of a stronger signal, the collector of the BC108 goes positive it takes the emitter of the BC158 positive of its base and the BC158 conducts. Its collector current then adds to the r.f. amplifier base current which passes through the resistors we've just discussed, thereby applying more forward bias to the r.f. transistor."

Dick looked at the circuit and frowned.

"Where does the BC158 get its

This  
saves  
this



Prevention is best -  
you know it makes sense!

Endorsements are expensive! Our unique radar spotting device gives earliest possible warning of radar speed checks - up to 1/3rd of a mile on give and take roads (1½ miles on motorways) and helps you to be a better and safer driver. Self-contained, only 10½ ozs. Clips on sun visor. **DON'T WAIT UNTIL IT'S TOO LATE - ORDER NOW.**

To: Belding & Bennett, 01-668 3255 & 01-660 2896, (Box 38), 45 Green Lane, Purley, Surrey.

Send me Spotters at £13.75p each

Enclosed PO/Cheque £.....

Name.....

Address.....

Phone No. ....

Details only: Send 4p in stamps.

Trade enquiries welcome.

The  
**RADIO CONSTRUCTOR**

**ANNUAL  
SUBSCRIPTIONS**  
to this magazine  
may be obtained  
through your  
newsagent  
or direct from the  
publishers  
**ONLY £2.70**  
per year, post free

Please send remittance with name and address and commencing issue required to:

**DATA PUBLICATIONS LTD**  
57 Maida Vale London W9 ISN

# BOOK REVIEWS

**COLOUR TELEVISION SERVICING.** By Gordon J. King, Assoc.I.E.R.E., M.I.P.R.E., M.R.T.S.  
329 pages, 6½ x 9½in. Published by Newnes-Butterworths. Price £4.40.

This new book from the prolific pen of Gordon J. King sets out to give a down-to-earth survey of PAL colour television receivers and their servicing. It is intended for the apprentice service engineer, the enthusiastic amateur and the experienced service engineer, and it will also be of help to the student preparing for the R.T.E.B. and City and Guilds television and radio servicing examinations.

The book is made up basically in three parts. The first of these deals with the working of the PAL and NTSC systems, the second discusses the circuits employed in all-transistor and hybrid receivers, whilst the third concentrates on fault symptoms and the appropriate remedial action. The text is backed by a liberal number of drawings and illustrations, including four pages of colour photographs. Both dual-standard and the later single-standard sets are described.

The first four chapters in the book deal with the science of colours, the colour camera, the shadowmask tube and the colour system overall. Further chapters are devoted to purity and convergence, timebases, e.h.t. circuits, power supply circuits, luminance and colour-difference amplifiers, grey-scale tracking, and receiver vision, chroma, reference generator and sound stages. The remaining chapters cover encoding and decoding, test instruments, test signals, fault area location, servicing in the workshop and in the field, tuned circuit alignment and faulty picture tube symptoms. The book closes with a comprehensive index.

**HOW TO CHOOSE AND USE TAPE RECORDERS.** By H. W. Hellyer, A.M.R.T.S., A.I.P.R.E., Assoc.A.E.S., M.S.S.M.  
239 pages, 5½ x 8½in. Published by Fountain Press, Ltd. Price £2.25.

"Who put the overalls in Mrs. Murphy's chowder?" This musical piece, believe it or not, provided the first demonstration of the use of high-coercivity magnetic recording tape, as developed by the Minnesota Mining and Manufacturing Company in America. It is mentioned in the book under review and demonstrates that a technical volume need not eschew the light-hearted touch. The author is, indeed, well-known for his humorous articles in the trade press.

He is also well-known for his serious writings on tape recording, these including his earlier book "Tape Recorder Servicing Manual". The present volume, which appears in the Fountain Press "How to Choose and Use" series, is primarily aimed at the potential purchaser of a tape recorder, and is intended to guide him through the bewildering varieties of design, function, facility and specification that he will encounter. Since a tape recorder has to be maintained after it has been bought, further material in the book deals with adjustment, cleaning and repair. The text is written at a level which can be appreciated by a handyman with a little electronic and mechanical background, but it does not hesitate to enter relatively complex fields where necessary, these being discussed and clearly explained without recourse to jargon or mathematics. The author's light touch keeps the book continually readable. An unusual feature is that there are probably more photographs in the book than line drawings. Very many mechanical points are, for instance, illustrated by photographs.

The subjects covered include the basic theory and practice of tape recording, the various types of recorder, microphones, slide and cine synchronising, recording techniques, and electrical and mechanical servicing. Where necessary, practical examples are taken from commercially manufactured designs.

**SEMICONDUCTORS: Basic Theory and Devices.** By I. J. Kampel.  
270 pages, 5½ x 8½in. Published by Newnes-Butterworths. Price £2.50.

Intended for readers with little experience of semiconductor devices, this book treats the subject at an apparently simple level. But, in so doing, it introduces the reader to  $E=mc^2$  on page 3, quantum theory on page 11 and Fermi levels on page 15! This is a refreshing approach, since it enables a true evaluation of semiconductor operation to be obtained right from the start.

The book commences with sections discussing atomic structure, energy bands, effects of impurities, the p.n. junction, diode characteristics and the static load line. Four sections dealing with the transistor follow, these being succeeded by two short looks at quantum theory and relativity. Next come photoelectric effects over the visible and infrared spectra, potential-distribution diagrams, f.e.t.'s, switching devices, specialised diodes and transistors, and other semiconducting devices. The book ends with four final sections covering mobility, lifetime, Hall Effect, manufacturing techniques, microelectronics and noise. The style is clear and lucid, simple mathematics being introduced very occasionally and only when entirely necessary.

In his preface the author states that it is his sincere hope that the book will give even the beginner a reasonable working knowledge of semiconductor theory, and will provide a negotiable bridge to the more advanced works available. The book should satisfy this aspiration more than adequately, and it should also enable its reader to appreciate that the transistor occupies only one small position in the wide-ranging field of physical science.



# Radio Topics

## By Recorder

Is this the first copy of *The Radio Constructor* that you have ever read? If so, welcome to the fold!

Every issue must have its quota of new readers and, in turn a proportion of these new readers must be beginners who are drawn to radio by the sheer magic of electronics.

There are few things so satisfying as making up an item of electronic equipment and having it perform just as the designer intended. Part of the fascination rests in the fact that one cannot see anything happening in the equipment itself. The electrons, whose movements constitute the current in the device which has just been built, are invisible. Indeed, their amplitude can only be measured by other electronic devices, such as testmeters and oscilloscopes.

### ART OF SOLDERING

The construction of electronic equipment presents few difficulties to anyone who is reasonably capable with his hands. In many cases the basic 'metal-bashing' required is merely the drilling of a few holes in an aluminium chassis or panel, and only a small quantity of relatively simple tools are required for this class of work. Some transistor designs don't require a chassis at all, the components being mounted on a piece of Veroboard, this consisting of a flat insulating material with parallel copper strips on one side. Component leads are passed through holes already pierced in the material and are soldered to the strips.

Which brings us to the question of soldering itself. Soldering is one

of the easiest processes of all to carry out, but it frequently provides the biggest hurdle for the newcomer. There is a knack to soldering which can only be acquired by practice. Half-an-hour's soldering with odd components is usually all that's required for life-long proficiency at the art!

There are several basic things to remember about soldering. First, solder isn't intended to cover a joint in the same way as sealing wax covers the knots in the string on a registered parcel. Solder, when hot, forms a *metallic* bond with the metals being soldered together. In a true solder joint there is an unbroken chain of metal molecules between any one part being jointed and the next. For the solder to form this metallic bond it must be able to reach the clean untainted surface of the metal. All metals tend to develop an oxide surface due to combination with the oxygen of the air; the solder must pass through this oxide layer to the pure metal underneath if it is to produce the essential soldered bond. This is where the flux comes in. Flux is a chemical whose purpose, when hot, is to break down the oxides on the metal being jointed, thereby enabling the solder to come into contact with the clean metal underneath.

If you go into a hardware shop you may see a variety of soldering fluxes for sale, these being either in paste or liquid form. *None of these fluxes is suitable for radio wiring work.* They are all liable to

leave a residue after soldering which is conductive or which may later become conductive, causing leakage currents to flow between adjacent connections. Some fluxes can even cause damage to insulation.

### RESIN-CORED SOLDER

For radio work it is necessary to use resin-cored solder. The resin, which is a specially developed flux, appears in the solder itself, with the result that it becomes automatically released when the solder melts. A good choice of resin-cored solder is Ersin Multicore Savbit alloy, which is obtainable at any good radio component shop. This alloy has the incidental advantage of incorporating a small percentage of copper, with a consequent lengthening of the life of the soldering iron bit. With normal solder there is a very small migration of copper from the bit at each joint which is made, causing a reduction in the length of the bit with time.

Most radio soldering work is easy because component lead-outs and tags have surfaces especially intended for good soldering. To make a joint, first place the two parts to be soldered together. Their junction is referred to as the 'work'. Place the end of a length of solder over the work and apply the tip of the iron. The solder will melt at once, allowing the iron bit to rest on the work itself. The hot flux in the solder is now released to do its job of breaking down oxides whereupon, as soon as the work reaches the cor-



"They told me you'd made a new wah-wah unit, old man!"

rect temperature, the solder flows over it and produces the requisite bond. It will probably be necessary to feed in a little extra solder to provide the amount required. Remove the iron as soon as the bond has been produced, as otherwise the work will become needlessly overheated. Make certain that the joint is not disturbed before the solder solidifies. Should the parts be moved just before, or at, the moment of solidification a poor joint results.

If the joint is good the solder will have run smoothly over the contours of the work, entering any crannies that may be present. This smooth covering of the work is the sign of a good joint. A poor joint has a 'bumpy' appearance with sharply raised edges at the periphery of the solder.

And that's all there is to it. After a little practice the making of a good solder joint becomes second nature. The practice is necessary not only to acquire the requisite skill but also to find just how much solder may not necessarily cause a poor joint but it can result in the production of a large 'blob' at the joint. Excessive solder also has a nasty habit of running off the joint into places where it's not wanted.

Like the solder, the soldering iron should also be of a type which is intended for radio work. It should be an electric iron, and a rating of some 15 to 30 watts will normally be adequate for home-constructor requirements. The tip should always be kept clean and well tinned, the latter being achieved by melting a small amount of solder onto it from time to time. This tinning of the bit is essential; if the bit is dirty, heat will not travel as quickly into the work as it should, with the result that the iron is applied for too long and overheating results.

## RECHARGEABLE BATTERIES

The accompanying photograph shows one of a new range of DEAC rechargeable batteries in action. This range is intended primarily for use with the Arriflex 16BL cine camera, but it is also suitable for portable power requirements not confined to camera equipment. In the photograph the batteries are carried in the leather case. Further details may be obtained from DEAC (Great Britain) Limited, Hermitage Street, Crewkerne, Somerset.

## SEA-WATER BATTERY

One is always bumping into something new in the electrical and electronic field, but the latest gadget I've encountered is one which has been in use, so I'm told, for twenty years!

It's a sea-water battery, intended

for emergency conditions such as occur after ditching from an aircraft or embarking on the ocean from a sinking ship. It also has applications for beacon, marine surface and underwater equipment. The battery uses sea-water as the electrolyte and the electrodes are silver chloride for positive and magnesium for negative. Potential per cell is about 1.2 volts. Sea-water batteries are manufactured by SAFT (United Kingdom) Limited, Castle Works, Station Road, Hampton, Middlesex.



*The electrical requirements for this ciné camera are met by the DEAC battery in the leather case. (See 'Rechargeable Batteries').*

## SOLDER SUCKING WICK

A new entrant in the solder removal stakes is Spirig Solder Sucking Wick, which is intended for the removal of solder from solder joints on printed circuit boards and similar locations. Many readers will be aware that the copper braiding from coaxial cable is useful in this respect; Spirig Solder Sucking Wick has the same basic capillary action but is very much more efficient.

The Solder Sucking Wick consists of a special flexible flux-impregnated copper braid with over 200 strands of 50 micron wire. It is supplied in 5 ft. lengths on a plastic spool dispenser, and is claimed to remove all the solder from any connection, whether it be post, hole or any other type.

In use, the wick is placed on the joint to be de-soldered. The tip of a 30-40 watt soldering iron is applied to the top side of the wick for 1 second, after which the wick and iron are removed together. The connection is then clean of solder, enabling the associated component to be removed. Also, the connection is left clean and corrosion-free, with only a non-corrosive and non-

conductive residue of flux. The connection is ready for re-soldering with no necessity for cleaning.

The Spirig Solder Sucking Wick is available from Electronics Division, J. J. Huber Limited, Fourth Way, Wembley, Middlesex.

## RELAYS

A relay is an electromechanical device and is, in consequence, potentially subject to mechanical faults and wear and tear as well as electrical faults. Its energising voltage is higher than its de-energising voltage and its contacts do not operate immediately when the coil voltage is applied or removed. Further, it is by modern standards a bulky component.

Yet, despite these disadvantages relays continue to be popular among both amateur and professional engineers. One reason, I suppose, is its inherent reliability in practice. The well-known P.O.3000 and P.O.600 constructions continue to be used in quantity, and manufacturers continue to improve on the basic design by the introduction of new materials and techniques. I remember P.O.3000 and P.O.600 relays in war-time equipment, and even in those days we looked upon them as devices which, provided they were enclosed to keep the dirt and dust out, simply pressed on without giving trouble.

What we are actually reaping, when we buy a relay these days, is the harvest of some three human generations of practical development and technical evolution. The relays of three to four decades ago had already reached a comfortable maturity so far as design was concerned, and all the problems of core, yoke and armature materials had been cleared up, as also had those of contact springs and the contacts themselves. There are, of course, very many relay designs other than the P.O.3000 and P.O.600, but I mention these two types because of their longevity. The manufacture of other relay types in this country must surely have benefited from the experience gained with these two basic types.

It looks as though the relay is going to continue in its not-so-small niche for quite a few more years to come, even though it should be giving way to modern semiconductor components. Perhaps we have a lot to thank our forefathers for! ■

## BOUND VOLUME No. 22,

AUGUST, 1968 — JULY, 1969,  
THE RADIO CONSTRUCTOR.  
All Copies have now been sold.

THE RADIO CONSTRUCTOR



## LATE NEWS

Times = GMT

Frequencies = kHz

### ● SURINAM

PZ1AV must be one of the most active stations on CW from this country. Heard often around the 14030 mark at 2000.

### ● COLOMBIA

Zone 9 is not often heard at the CW end of 14MHz these days but HK7UL has been active on 14015 from around 2015 onwards.

### ● GUANTAMANO BAY

KG4EO is often to be heard using the CW mode around 2000 on 14040 busily working into the States.

### ● SOUTH AFRICA

SSB listeners should hover around 14190 at 1900 or so to log this country in the form of ZS5EH. For CW addicts, try 14060 around 2000 for the signals of ZS6ME.

### ● ANGOLA

Heard of late, using SSB from Zone 36. CR6JA on 14180 at 1910 and CR6TP on 14210 at 2225.

### ● MONTSERRAT

VP2MY can often be heard using SSB on, or around, 14190 at 2230.

### ● GRENADA

In the same general area as Montserrat is Grenada. For signals from the latter country listen for VP2GAR using SSB on 14190 at 1900.

### ● ZAMBIA

9J2JY heard often of late using 14180 SSB around 1915 working the UK.

### ● S. KOREA

HLK41 Seoul is reported by BADX on the regular 15155 (19.78m) 50kW channel with news in English to 0642, commentary and identification at 0647 and songs to 0657. The English schedule, to Europe is from 0630 to 0700 on this channel and from 1330 to 1400 on 15430 (19.44m) 50kW. The news in English in the European Service is at 0630 and at 1330. The address is - The Korean Broadcasting System, Central Broadcasting Station, Yejangdon 8, Chungku, Seoul.

### ● N. VIETNAM

A new channel for Hanoi, according to the BADX, is 14987.5, heard with anthem and announcements in Vietnamese at 2028. (BADX)

### ● NIGERIA

Radio Nigeria now signs on at 0545 with interval signal on 15200 (19.74m) 100kW. The 15185 channel appears to have been vacated. (BADX)

## MORE NEWS

According to the BADX, Abu Dhabi can often be heard from 1900 to 1950 on 4988. The identification is "Idha'at el Aby Dhabi . . . Arabia".

On 5345 The Voice of the Free South, believed to be a Yemeni Royalist station, has been logged with the identification "Huna Idha' at el Janub al Yemen al Sawat". (BADX).

The S.Yemen Broadcasting Service, Aden, on 5060 identifies as "Huna Aden Idha'at el Gumboriya't al Yemen al Demokrativa Ash-shahiya" and has been heard with news in Arabic at 2130. (BADX).

ORTF Reunion is reported by BADX to have a new sign-off time of 1900 on 4807, when it was logged with the National Anthem preceded with closing announcements in a variety of languages.

Belize, British Honduras, has been logged on 3300 at 0045 with frequent announcements and commercials. (BADX).

AUGUST 1971

## LAST LOOK ROUND

According to the British Association of Dx'ers (BADX), Radio Gambia has a schedule as follows - from Monday to Friday 0630 to 0800, 1200 to 1400 and from 1700 to 2300. Saturdays from 0630 to 0900, 1200 to 1400 and from 1700 to 2300. Sundays from 0900 to 1400 and from 1700 to 2300 on 4820 (3kW).

Other items of news from BADX - HCEH3 Loja has moved from 4775 to 4733. HIAS S.Domingo has moved from 4795 and is now on 4790. HCCR1 Quito has moved from 4930 to 4896. CP105 Trinidad, Bolivia, has moved from 4955 to 4958. Radio Liberation, "Voice of the Provisional Revolutionary Government of S.Vietnam" can be heard on 7415 at 1045.

The address of the British Association of Dx'ers is - 16, Ena Avenue, Neath, Glam. Prospective members must be *actively* engaged in Broadcasting band listening and must report on a *regular* basis.

# TV

## FAULT FINDING MANUAL for 405/625 LINES



50p

POSTAGE 6p

### REVISED & ENLARGED

EDITED BY J. R. DAVIES

124 pages

Over 100 illustrations, including 60 photographs of a television screen after the appropriate faults have been deliberately introduced.

Comprehensive Fault Finding Guide cross-referenced to methods of fault rectification described at greater length in the text.

# UNDERSTANDING TELEVISION

by

J. R. DAVIES

Over 500 pages  
300 diagrams

£1-87

POSTAGE  
20p



UNDERSTANDING TELEVISION deals with:

- Principles of 405 line reception
- Principles of 625 line reception
- Nature of the television signal
- Receiver tuner units
- A.F. and video amplifiers
- Deflector coil assemblies
- Automatic gain and contrast control
- Receiver aerials
- The cathode ray tube
- Receiver i.f. amplifiers
- Vertical and horizontal timebases
- Synchronising
- Power supply circuits
- Colour television
- **COLOUR TELEVISION** – 80 page section deals comprehensively with this subject

The reader is required to have only a basic knowledge of elementary radio principles. The treatment is non-mathematical throughout, and there is no necessity for any previous experience in television whatsoever. At the same time UNDERSTANDING TELEVISION is of equal value to the established engineer because of the very extensive range it covers and the factual information it provides.

**To Data Publications Ltd., 57 Maida Vale, London, W.9 1SN**

Please supply the 4th revised edition of TV FAULT FINDING, Data Book No. 5.....

Please supply UNDERSTANDING TELEVISION, Data Book No. 17.....

I enclose cheque/crossed postal order for..... (Tick which book is required)

NAME.....

ADDRESS.....

(BLOCK LETTERS PLEASE)



# SMALL ADVERTISEMENTS

Rate: 4p (9d.) per word. Minimum charge 60p (12/-).  
Box No. 10p (2/-) extra.

Advertisements must be prepaid and all copy must be received by the 4th of the month for insertion in the following month's issue. The Publishers cannot be held liable in any way for printing errors or omissions, nor can they accept responsibility for the *bona fides* of advertisers. (Replies to Box Numbers should be addressed to: Box No. —, *The Radio Constructor*, 57 Maida Vale, London, W9 1SN

**BUILD IT** in a **DEWBOX** robust quality plastic cabinet 2in. x 2½in. x any length. S.A.E. for details. D.E.W. Ltd., 254 Ringwood Road, Ferndown, Dorset. Write now - right now.

**SERVICE SHEETS (1925-1971)** for Televisions, Radios, Transistors, Tape Recorders, Record Players, etc., by return post, with free Fault-Finding Guide. Prices from 5p. Over 8,000 models available. Catalogue 13p. Please send S.A.E. with all orders/enquiries. Hamilton Radio, 54 London Road, Bexhill, Sussex. Telephone: Bexhill 7097.

**CONSTRUCTORS USED COMPONENTS.** Parcels at 50p each, including postage, 50 assorted resistors. 50 assorted capacitors. 10 electrolytic capacitors. 10 assorted knobs. 5 assorted potentiometers. 20 assorted valve bases. Please state which parcel required. Broadcast type twin gang variable capacitors at 18p each. Speakers at 50p each. 7 inch, 5 inch, 5½ x 3½ inch elliptical. P. & P. 18p. Box No. G142.

**NEW CATALOGUE NO. 18**, containing credit vouchers value 50p, now available. Manufacturers new and surplus electronic and mechanical components, price 23p post free. Arthur Sallis Radio Control Ltd., 28 Gardner Street, Brighton, Sussex.

**SERVICES FOR CONSTRUCTORS:-** Etched aluminium fascia panels to specification. Plain aluminium panels to individual sizes. Labels, dials, nameplates. Instrument scales. Drafting tapes for printed circuit layouts. S.A.E. for details. R. A. Marsh, 29 Shelbourne Road, Stratford on Avon, Warwick.

**FOR SALE:** Txing type variable capacitor, 50-110pF, ½in. spacing £1. Tannoy P.A. Mic, £1.50. 1.5 - 3MHz Command receiver, £2. Motor generator, 12V 4A in, 400V .05A out, £1.50. Type 3 T/P ink rollers, 25p bottle. 200ft. Super-8 cine reels, 25p. Box No. G144.

**VHF KIT, 80-178MHz.** Receiver, tuner, converter. World Wide Sales. £4.13 or S.A.E. for literature. Johnsons (Radio C), Worcester, WR1 2DT.

**FOR SALE:** *International Encyclopaedia of Stamps.* Published by IPC Magazines Ltd. Vol. 1, parts 1 to 14. Vol. 2, parts 1 to 13. Cover price 23p each part. Will sell at £2 per volume. Box No. G149.

**RECORD TV SOUND** using our loudspeaker isolating transformer. Provides safe connection to recorder. Instructions included. 70p plus 10p P. & P. Crowborough Electronics (R.C.), Eridge Road, Crowborough, Sussex.

**TO CLEAR:** *Life World Library and Life Sunday Times World Library.* All at 30p post paid. South-Greece, Mexico, Russia, Italy, Britain, Japan, Brazil, France, India & Germany. Box No. G150.

**5 TRANSISTOR 1 WATT AUDIO AMPLIFIERS**, for 7½-15V supply. Standard 3 ohm output. Only £1 each. Manley, 13 Randisbourne Gardens, Bromley Road, London S.E.6.

**SEND LARGE S.A.E. for free components list.** Pair of miniature toby jug ornaments given free with list during August. Hope, Pentalardd, Maesyrcugiau, Pencader, Carmar.

(Continued on page 61.)

# BENTLEY ACOUSTIC CORPORATION LTD.

38 Chalcot Road, Chalk Farm  
LONDON, N.W.1.  
01-722-9090

The Old Police Station  
Gloucester Road  
LITTLEHAMPTON Sussex  
PHONE 6743

Please forward all mail orders to Littlehampton

5Z4G	.35	EBF89	.28	EY51	.34	PL84	.31	UF89	.28	BF180	.30
6A Q5	.22	EC92	.35	EY87/6	.31	PL504/		UL41	.39	BY100	.18
6AT6	.40	ECC32		EZ40	.40	PL500/	.64	UL41	.32	BY101	.15
6B16	.39		1.58	EZ80	.22	PL508	.90	UM80	.33	BY105	.18
6/30L2	.57	ECC33		EZ81	.23	PL509	1.30	UY41	.38	BY114	.18
6BR7	.79		1.58	HVR2	.53	PL802	.75	UY85	.26	BY126	.15
6BW6	.72	ECC81	.16	KTW62	.63	PX4	1.16	AA119	.15	BY127	.18
6BW7	.57	ECC82	.20	KT66	.82	PX25	1.16	AC113	.25	BY210	.25
6BZ6	.31	ECC83	.23	KT81	2.00	PY33/2	.50	AC127	.17	BY211	.25
6F14	.44	ECC84	.28	KT88	1.70	PY81	.25	AC154	.20	BY212	.25
6F23	.70	ECC85	.25	PX86	.49	PY82	.25	AC154	.25	BY213	.25
6F28	.70	ECC86	.40	PX88	.49	PY83	.27	AC156	.20	OA70	.15
6L6GT	.39	ECC88	.35	PC95	.53	PY88	.33	AC157	.25	OA79	.09
9D7	.78	ECC189		PC97	.38	PY500	.95	AD140	.36	OA81	.09
10C1	1.25			PC900	.35	PY800	.35	AD149	.50	OA90	.13
10F18	.35	ECF80	.28	PC884	.30	PY801	.34	AD161	.45	OA91	.09
12A6	.63	ECF82	.28	PC885	.29	QVQV3/		AD162	.45	OA95	.09
30C15	.62	ECF86	.65	PCC88	.44	10	1.20	AF114	.25	OA200	.09
30C17	.79	ECH42	.62	PCC89	.46	R19	.31	AF115	.15	OA202	.10
30C18	.63	ECH81	.28	PCC189	.49	U18/20	.75	AF119	.23	OC23	.38
30F5	.70	ECH83	.40	PCF80	.29	U19	1.73	AF121	.30	OC24	.38
30FL1	.62	ECH84	.36	PCF82	.31	U25	.65	AF126	.18	OC28	.38
30FL2	.75	ECL80	.31	PCF84	.40	U26	.59	AF139	.65	OC26	.24
30FL14	.70	ECL82	.31	PCF86	.45	U191	.60	AF180	.48	OC28	.60
30L15	.60	ECL83	.52	PCF200	.67	U251	.70	AF186	.55	OC35	.32
30L17	.71	ECL84	.55	PCF801	.32	U301	.40	AF239	.38	OC36	.43
30P4/19	.60	ECL86	.37	PCF802	.40	U801	.95	BA102	.45	OC38	.43
30P4MR		EF22	.63	PCF805	.59	UABC80		BA115	.23	OC44	.10
	.98	EF41	.58	PCH200				BA116	.25	OC45	.11
30P12	.69	EF80	.23			UBC81	.40	BA129	.13	OC46	.15
30P11	.61	EF85	.28	PCL82	.33	UBF80	.29	BA130	.10	OC70	.13
30P13	.78	EF86	.31	PCL83	.60	UBF89	.31	BC107	.13	OC71	.11
DY87/6	.26	EF89	.24	PCL84	.35	UC92	.35	BC108	.13	OC72	.11
DY802	.38	EF91	.17	PC805/		UC884	.34	BC113	.25	OC74	.23
E8CC	.60	EF183	.27	85	.42	UC885	.35	BC118	.23	OC75	.11
E92C	.40	EF184	.30	PCL86	.40	UCF80	.35	BCY38	.23	OC78	.15
EABC80		EH90	.38	PD500	1.44	UCH21	.60	BCY39	.25	OC78D	.15
	.31	EL34	.46	PEN45	.35	UCH42	.61	BCZ11	.38	OC81	.11
EAF42	.49	EL41	.54	PEN45DD		UCH81	.31	BD119	.45	OC81D	.11
EB34	.20	EL84	.23			UCL82	.34	BFY50	.23	OC82	.11
EB91	.11	EL95	.34	PFL200	.54	UCL83	.49	BFY51	.19	OC83	.20
EBC41	.48	EM80	.38	PL36	.47	UF41	.50	BFY52	.20	OC84	.24
EBC81	.33	EM81	.40	PL81	.44	UF80	.35	BF159	.25	OC123	.23
EBF80	.31	EM84	.32	PL82	.31	UF85	.34	BF163	.20	OC139	.23
EBF83	.38	EM87	.36	PL83	.33	UF86	.63	BF173	.38	OC140	.95

All goods are unused and boxed, and subject to the standard 90-day guarantee. Terms of business: Cash or cheque with order only. No C.O.D. orders accepted. Post/packing charge 0.03 per item, subject to a minimum of 0.09. Orders over 5.00 post free. All orders despatched same day by first class mail. Complete catalogue with conditions of sale 0.07 post paid. Any parcel insured against damage in transit for only 0.03 extra per order. Business hours 9 a.m.-5.30 p.m. Sats. 9 a.m.-1 p.m. Littlehampton closed Sats. No enquiries answered unless S.A.E. enclosed for reply.



EST. 1891

## TECHNICAL TRAINING in Radio, Television and Electronic Engineering

First class opportunities in Radio and Electronics await the ICS trained man. Let ICS train YOU for a well-paid post in this expanding field.

ICS courses offer the keen, ambitious man the opportunity to acquire, quickly and easily, the specialized training so essential to success.

Diploma Courses in Radio, TV Engineering and Servicing, Colour TV Servicing, Electronics, Computers, etc. Expert coaching for:

- \* C.&G. TELECOMMUNICATION TECHNICIANS CERTS
- \* C.&G. ELECTRONIC SERVICING
- \* R.T.E.B. RADIO AND TV SERVICING CERTIFICATE
- \* RADIO AMATEURS EXAMINATION
- \* RADIO OPERATOR CERTIFICATES

Examination Students Coached until Successful.

### NEW SELF-BUILT RADIO COURSES

Build your own 5-valve receiver, transistor portable, signal generator, multi-test meter—all under expert guidance. POST THIS COUPON TODAY and find out how ICS can help YOU in your career. Full details of ICS courses in Radio, Television and Electronics will be sent to you by return mail.

Member of Association of British Correspondence Colleges

### INTERNATIONAL CORRESPONDENCE SCHOOLS

Dept. 248, Intertext House, Stewarts Road, London, SW8 4UJ

Name..... Age.....

BLOCK CAPITALS PLEASE

Address.....

8.71

# One year's electronics experience + ONC or C & G?

Then become a Radio Technician with the National Air Traffic Services. You would work on the installation and maintenance of a wide range of sophisticated electronic systems and specialised equipment throughout the U.K. You would be involved with RT, Radar, Data Transmission Links, Navigation Aids, Landing Systems, Closed Circuit T.V. and Computer Installations. You could also work on the development of new systems.

To qualify for entry to our training course you must be aged 19 or over, have at least one year's experience in electronics and preferably O.N.C. or C. & G. (Telecoms). Your starting salary would be £1,143 (at 19) to £1,503 (at 25 or over), scale max. £1,741 - shift duty allowances. Good career prospects.

*Send NOW for full details of how you can become a Radio Technician. Complete the coupon and return to A. J. Edwards, C.Eng., MIEE, Room 705, The Adelphi, John Adam Street, London WC2N 6BQ, marking your envelope 'Recruitment'.*

I meet the requirements, please tell me more about the work of a Radio Technician.

NAME \_\_\_\_\_

ADDRESS \_\_\_\_\_

(A/RC/18)

Not applicable to residents outside the United Kingdom.

**NATS**  
National Air Traffic Services

## NEW STYLE SELF-BINDER

for "The Radio Constructor"

The "CORDEX" Patent Self-Binding Case will keep your issues in mint condition. Copies can be inserted or removed with the greatest of ease. Rich maroon finish, gold lettering on spine.

Specially constructed Binding Cords are made from Super Linen of great strength, very hard twisted and twice doubled. They are attached to strong RUSTLESS Springs under tension, and the method adopted ensures PERMANENT RESILIENCE of the Cords. Any slack that may develop is immediately compensated for and the Cords will always remain taut and strong. It is impossible to overstretch the springs, as a safety check device is fitted to each.

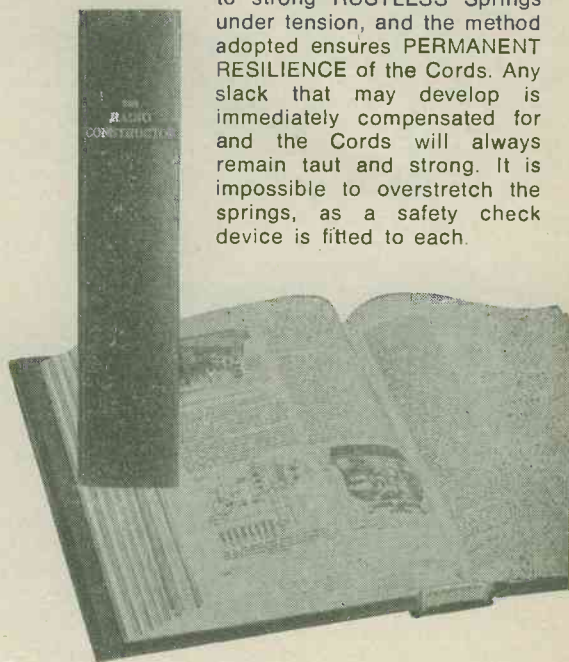

PRICE **75p** Postage 10p

Available only from:-

**Data Publications Ltd.**  
57 Maida Vale London W9 1SN



## SMALL ADVERTISEMENTS

(Continued from page 59)

**"MEDIUM WAVE NEWS"** Monthly during Dx season - Details from: K. Brownless, 7 The Avenue, Clifton, York.

**POSTAL ADVERTISING?** This is the Holborn Service. Mailing lists, addressing, enclosing, wrapping, facsimile letters, automatic typing, copy service, campaign planning, design and artwork, printing and stationery. Please ask for price list. - The Holborn Direct Mail Company, Capacity House, 2-6 Rothsay Street, Tower Bridge Road, London, S.E.1. Telephone: 01-407 1495.

**FOR SALE:** Specialist stamp collection. Space, Railway Centenary, ITU, IGY, etc. issues. Catalogue value approx. £150. Offers? S.A.E. for details. Another collection of early Space issues £25 o.n.o. Small general collection at £5. Box No. G151.

**ENGRAVING.** Easy constructed device gives professional results. Suitable for perspex organ, tabs etc. Large drawings and instructions 80p, post paid. S. Smyth, 234 Dumbarton Road, Partick, Glasgow W.1.

**WANTED:** Marine type sextant. Details & price to Box No. G152.

**HOLIDAY ACCOMMODATION.** Burwood Lodge Hotel, Dawlish Road, Teignmouth, S. Devon. Especially for parents with young children. Facing south, on the cliffs, direct access by private path to sea. Mothers' kitchen, automatic washing machines, baby listening service. Licensed lounge. Ample free parking.

**CRYSTALS.** Marine frequencies. 2381, 2089, 2306, in holders with  $\frac{1}{2}$ in. pin spacing £2 each. Box No. G154.

**JOIN THE INTERNATIONAL S.W. LEAGUE.** Free services to members including Q.S.L. Bureau, Amateur and Broadcast Translation, Technical and Identification Dept. - both Broadcast and Fixed Stations, DX Certificates, contests and activities for the SWL and transmitting members. Monthly magazine, *Monitor*, containing articles of general interest to Broadcast and Amateur SWLs, Transmitter Section and League affairs, etc. League supplies such as badges, headed notepaper and envelopes, QSL cards, etc., are available at reasonable cost. Send for League particulars. Membership including monthly magazines, etc., £1.75 per annum. Secretary ISWL, 1 Grove Road, Lydney, Glos., GL15 5JE.

**RELAYS.** Sigma type 72AOZ, octal base, £1.50; Carpenter polarised, £1; D164816, £1.50. Box No. G155.

**FREE GIFT** when you request our quality stamps, supplied on approval. Generous discounts. Details from: Watson's Philatelic Service, 6 Beech Avenue, Brentwood, Essex.

**WANTED:** Books, P.E. back numbers, etc., on electronic organs. Also components, instruments, AVO 8, etc. Hemming, 78 Oxford Street, Bristol 3. Telephone: 77524.

**IF YOU HAVE ENJOYED A HOLIDAY** on the Norfolk Broads, why not help to preserve these beautiful waterways. Join the Broads Society and play your part in determining Broadlands future. Further details from:- The Hon. Membership Secretary, The Broads Society, "Icknield", Hilly Plantation, Thorpe St. Andrew, Norwich, NOR 85S.

**100 DIFFERENT WORLD STAMPS.** 40% large, 25p. Pair of miniature toby jug ornaments given free with each order. Hope, Pentalardd, Maesyrcrugiau, Pencader, Carm. S.

**WORLD DX CLUB** covers all aspects of SWLing on Amateur and Broadcast Bands through its monthly bulletin "Contact". Membership costs £1.38 a year. Enquiries to Secretary, WDXC, 11 Wesley Grove, Portsmouth, Hants., PO3 5ER.

(Continued on page 63)

# RADIO OPERATORS

Do you Hold  
PMG II OR PMG I OR  
New General Certificate  
OR had Two Years' Radio  
Operating Experience?

## LOOKING FOR A SECURE JOB WITH GOOD PAY AND CONDITIONS?

Then apply for a post with the Composite Signals Organisation-these are Civil Service posts, with opportunities for service abroad, and of becoming established i.e. Non-Contributory Pension Scheme.

Specialist Training Courses (Free accommodation) starting January, April and September 1972.

If you are British born and resident in the United Kingdom write **NOW** for full details and application form from:

Recruitment Officer  
Government Communications  
Headquarters,

Oakley,  
Priors Road,  
CHELTENHAM,  
Glos., GL52 5AJ.  
Tel: Cheltenham 21491. Ext. 2270.

# TOO MUCH STOCK!!

—to list on one advertisement!

Yes, LST would need half this magazine to show their full range.



But 5p for postage will bring you our FREE components catalogue. 44 pages of semiconductors, integrated circuits, passive components, tools, kits, etc., etc.

Send this coupon to:

LST ELECTRONIC COMPONENTS LTD  
MAIL ORDER DEPT RC  
7 COPTFOLD ROAD  
BRENTWOOD  
ESSEX

Please send your "cat" to:

Name: .....

Address: .....

## FREE TO AMBITIOUS ENGINEERS

—THE LATEST EDITION OF ENGINEERING OPPORTUNITIES

### SEND FOR YOUR FREE COPY TO-DAY

ENGINEERING OPPORTUNITIES is a highly informative 74 page guide to the best paid engineering posts. It tells you how you can quickly prepare at home for a recognised engineering qualification and outlines a wonderful range of modern Home Study Courses in all branches of Engineering. This unique book also gives full details of the Practical Radio & Electronics Courses administered by our Specialist Electronics Training Division — explains the benefits of our free Appointments and Advisory service and shows you how to qualify for five years promotion in one year.

### 'SATISFACTION OR REFUND OF FEE' TERMS

We give a written agreement that if after completing one of our courses, you do not pass your examination or are dissatisfied in any other way we will refund your complete fee.

### PRACTICAL EQUIPMENT INCLUDING TOOLS

The specialist Electronics Division of B.I.E.T. NOW offers you a real laboratory training at home with all the practical equipment you need, plus Basic Practice and Theoretical Courses for beginners in Radio, TV, Electronics, etc.

### BRITISH INSTITUTE OF ENGINEERING TECHNOLOGY

Dept. (B10), Aldermaston Court, Reading RG7 4PF

— SEND OFF THIS COUPON TO-DAY! —

Tick subjects that interest you:

- AMSE (Elec)  City & Guilds Certificate  RTEB Certificate   
Radio Amateurs' Exam  DMG Certificate  Colour TV   
Electronic Engineering  Computer Electronics  Radio and TV  
Servicing  Practical Electronics  Practical TV & Radio   
Please send booklets & full information without cost or obligation.



NAME..... AGE.....

ADDRESS .....

OCCUPATION .....

To: BIET Dept. B10, Aldermaston Court, Reading RG7 4PF

# INTERNATIONAL SHORT WAVE LEAGUE



Membership £1.75 (35s. 0d.) per annum (U.S.A. \$5.00) including 12 monthly issues of *Monitor* — the League journal. Including free use of all Services, QSL Bureau etc.

## THE LARGEST S.W.L. ORGANISATION IN THE WORLD

For full details write to:

The Secretary,  
I.S.W.L.,  
1, GROVE ROAD, LYDNEY,  
GLOS. GL15 5JE.

## To All Users of Industrial Electronics

Take advantage of our very competitive prices and high quality workmanship.

DESIGN AND CONSTRUCTION OF  
INDUSTRIAL ELECTRONICS EQUIPMENT.  
INDUCTION HEATING GENERATORS. METAL  
DETECTORS, POWER SUPPLIES, AUTOMATION  
AND CONTROL EQUIPMENT.

HIGH QUALITY  
SHORT DELIVERY TIMES,  
TWO YEARS GUARANTEE

DESIGNS CONSTRUCTED TO  
CUSTOMERS OWN SPECIFICATIONS.

WRITE FOR FULL DETAILS TO:-

“E.B.E.H. A. KYPRIOTIS”

## LABORATORIES OF INDUSTRIAL ELECTRONICS

OFFICE  
ANDROMAHIS 50, KALLITHEA  
ATHENS, GREECE

FACTORY  
PAPAFLESSA 3, TSAKOS  
AGHIA PARASKEVI  
ATHENS, GREECE



## SMALL ADVERTISEMENTS

(Continued from page 61)

**MAGAZINES FOR SALE:** "The Radio Constructor" - 1967 except June & October, 90p; all 1968 issues £1; all 1969 issues £1; or the lot £2.75 to clear. "Practical Wireless" - all 1969 issues £1; "Wireless World" - 1968, all except January, May, July & October; also copies of March, April, May & June 1969; the lot £1.50 to clear. Prices include postage. All in good condition. Box No. G162.

**ARE YOU A MOTORING ENTHUSIAST?** The Seventy Motor Club caters for all types of motor sport-racing, rallies, hill climbs, etc. Monthly Bulletin free to members. For full details write to: The General Secretary, Colin Peck, "Dancers' End", St. Winifred's Road, Biggin Hill, Kent.

**VALVES TO CLEAR:** 801-A, VT136, VT62, DK91, T20, UX865S, HP4106, 41MP, 6B4G, 10LD, N142, U142, 10F9, TH141, 3ML, UY41, 171DDP, 3S4, VR91. All at 13p each postage paid. Box No. G165.

**MAGAZINES FOR SALE/EXCHANGE.** Radio Constructor, Practical Electronics, Practical Television. Single issues. Reasonable prices. All enquiries answered. Wanted: Practical Wireless. Charnley, 18 Nether Street, Finchley, London N12 7NL.

**ESSEX GARDENERS.** Buy your bedding and rock plants, shrubs, etc., also cacti from May's Nurseries, 608 Rayleigh Road, Hutton, Brentwood, Essex. Callers only. Monday to Saturday.

**SELLING UP.** Oscilloscope £30, solid-state voltmeter £15, CR Bridge £10. All nearly new. Large quantity components, many unused, £15 to clear. Box No. G166.

**FOR SALE:** Old Scott-Taggart hand-made radio, in old radiogram cabinet. In good order. Offers invited. Owen, 62 Minstead Road, East Howe, Bournemouth, Hants. Telephone: Northbourne 2745.

**PRINTED CIRCUITS.** Capacity now available for prototypes or production runs. Artworks, Photographics, Etched Boards, and Assembly. Fast turn round. Send S.A.E. for quotations. Also copper laminated fibreglass board single sided 1½p per square inch, double sided 2p per square inch, any size cut. Minimum order 50p. P. & P. plus 10%. Systematics, 18 Pennine Road, Millbrook, Southampton, Hants.

**TOP 20 TV VALVES,** 10p. PL504, PL36, PY33, 15p. P. & P. 4p per valve, over 12 valves post free. Guaranteed tested, ex-equipment, individually boxed. Resistors and capacitors all values and sizes. Leading manufacturers components and hi-fi equipment 10% or more off. 13 amp plugs 12p. Mains fuses 20p for 10. Tools, etc. P. & P. extra on all items. Trade enquiries welcomed, discount for quantity. S.A.E. for list. L. & D. Components Ltd., 71 Westbury Avenue, Wood Green, London N.22. Telephone: 01-888 2701.

**FREQUENCY LIST TRANSFERS.** We have a limited supply of sheets of Dial Frequency Transfers in black. Short Wave frequencies 1.8Mc/s to 32Mc/s and 144Mc/s and 146Mc/s. Includes amateur band marker frequencies at 100kc/s points and other short wave frequencies from 2 to 32Mc/s at every 500kc/s points. Each frequency is repeated. Two sheets for 5p, five sheets for 10p, postage 2½p. Data Publications Ltd., 57 Maida Vale, London W9 1SN.

### JOHN SAYS . . .

**RING MODULATOR** by Dewtron is professional, transformerless, 5 transistor, has adjustable F1/F2 rejection. Module £7. Unit £8.90 WAA-WAA Pedal kit of all parts, incl. all mechanics & instr. ONLY £2.45. AUTO RHYTHM from Dewtron modules. Simple unit for waltz, foxtrot, etc. costs £16.55 in modules. ORGAN PERCUSSION and other fascinating effects. Send 15p for illust. list. D.E.W. LTD., 254 Ringwood Road, FERNDOWN, Dorset.

# PLAIN-BACKED NEW STYLE SELF-BINDERS

for your other magazines

(max. format 7½" x 9½")

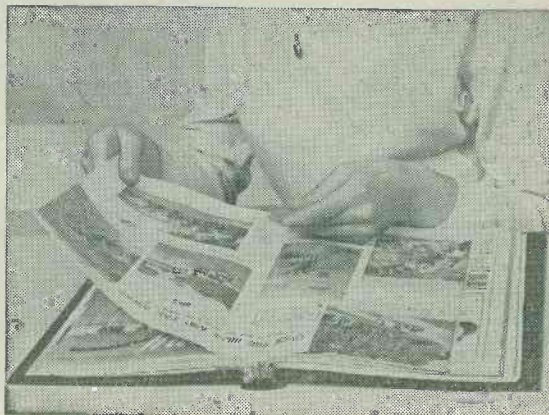

The "CORDEX" Patent Self-Binding Case will keep your copies in mint condition. Issues can be inserted or removed with the greatest of ease. Specially constructed Binding cords are made from Super Linen of great strength, very hard twisted and twice doubled. They are attached to strong RUSTLESS Springs under tension, and the method adopted ensures PERMANENT RESILIENCE of the Cords. Any slack that may develop is immediately compensated for, and the Cords will always remain taut and strong. It is impossible to over-stretch the springs, as a safety check device is fitted to each.

**COLOURS: MAROON OR GREEN**

(If choice not stated, colour available will be sent)

**PRICE 70p** Postage 10p

Available only from:-

**Data Publications Ltd.**  
57 Maida Vale London W9 1SN

# CHASSIS and CASES by



H. L. SMITH & CO. LTD.  
287/9 Edgware Road  
London W2 1BE  
TEL: 01-723 5891

## BLANK CHASSIS

FOUR-SIDED 16 SWG ALUMINIUM

Size	Price	Base	Size	Price	Base
6x4x2"	34p	17p	10x8x2"	66p	30p
7x4x1"	33p	18p	12x7x2"	66p	33p
7x5x2"	40p	19p	12x9x2"	76p	38p
8x4x2"	38p	19p	13x8x2"	76p	38p
8½x5½x2"	44p	21p	14x7x3"	80p	36p
9x7x2"	50p	26p	14x10x2½"	88p	47p
10x4x2½"	50p	21p	15x10x2½"	92p	50p
12x4x2½"	55p	22p	17x10x3"	£1.10	55p
12x5x3"	66p	26p			

## CASES

ALUMINIUM, SILVER  
HAMMERED FINISH

Type	Size	Price	Type	Size	Price
N	8x6x2"	£1.00	W	12x7x7"	£2.00
N	6x6x3"	£1.05	W	15x9x8"	£3.15
N	4x4x2"	80p	Y	8x6x6"	£2.25
U	4x4x4"	95p	Y	12x7x7"	£2.80
U	5½x4½x4½"	£1.15	Y	13x7x9"	£3.15
U	8x6x6"	£1.45	Y	15x9x7"	£3.35
U	9½x7½x3½"	£1.55	Z	17x10x9"	£4.15
U	15x9x9"	£3.00	Z	19x10x8½"	£4.50
W	8x6x6"	£1.90			

\*Height  
Type N has removable bottom. Type U removable bottom or back. Type W removable front. Type Y all screwed construction. Type Z removable back and front. Plus p. & p.

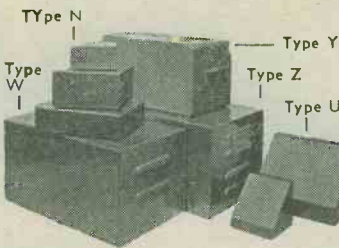

### TO FIT OUR CASES

7x5½x1½"	38p	21p	12x6½x2"	60p	33p
7x5½x2"	43p	21p	14x8½x2"	74p	44p
11x6½x1½"	55p	30p	15½x9½x2½"	94p	52p
11x6½x2"	55p	30p	17½x9½x2½"	£1.05	59p

Plus post & packing

PANELS: Any size up to 3ft. at 36p sq. ft. 16 s.w.g. (18 s.w.g. 32p). Plus postage and packing

## CIRCUITS! CIRCUITS!

Ten exciting circuits per month with instructions to build. Every month a completely new set. This month's circuits cover

**"RECEIVERS OF ALL KINDS"**  
only 50p per set of ten

Postage and packing free

Free Data and Technical A-Z cards. Build up the complete set month by month.

Cheques and PO's to Dept. R/C, Photonics, 3 Whitehall Gardens, London, E.4. *sae for details*

**YUKAN** SO PROFESSIONAL THE  
**SELF-SPRAY** YUKAN AEROSOL WAY-

Get these air drying **GREY HAMMER**  
**NOW!** OR **BLACK WRINKLE**  
*(CRACKLE) finishes*

Yukan Aerosol spraykit contains 453g. fine quality, durable easy Instant spray. No stove baking required. Hammers available in grey and blue, 80p can. pd. Modern Eggshell Black Wrinkle (Crackle) producing a 3D textured finish. 90p can. pd. all at 85p per push-button self-spray can at our counter. Also durable, heat and water resistant Black Matt finish (33p, self-spray cans only) 76p can. pd.

**SPECIAL OFFER:** One can plus optional translatable snap-on trigger handle (value 26p) for 36p can. pd. Choice of 13 self-spray plain colours and primer (motor car quality) also available.

Please enclose cheque or crossed P.O. for total amount direct to:  
**DEPT: N/4 YUKAN, 307a EDGWARE ROAD, LONDON W2 1BN**

We supply many Government Departments, Municipal Authorities, Institutes and Leading Industrial Organisations--We can supply you too. *Now British--even better*

Other Yukan Air Drying Aerosols, 453g at 90p can. pd.  
Zinc Chromate  
Clear Lacquer  
Metallics: Grey, Blue.

## DATA BOOK SERIES

- DB5 TV FAULT FINDING**  
124 pages. Price 50p, postage 6p.
- DB16 RADIO CONTROL FOR MODELS**  
192 pages. Price 75p, postage 8p.
- DB17 UNDERSTANDING TELEVISION**  
512 pages. Price £1.88, postage 20p.
- DB18 AUDIO AMPLIFIERS**  
128 pages. Price 53p, postage 6p.
- DB19 SIMPLE SHORT WAVE RECEIVERS**  
140 pages. Price 80p, postage 6p.

I enclose Postal Order/Cheque for.....in payment for.....

NAME.....

ADDRESS.....

*(Please use Block Capitals for both name and address)*

*Postal Orders should be crossed and made payable to Data Publications Ltd.*

*Overseas customers please pay by International Money Order.*

*All publications are obtainable from your local bookseller.*

*Data Publications Ltd., 57 Maida Vale, London W9 1SN*

Please mention **THE RADIO CONSTRUCTOR** when writing to advertisers



### Time-Frequency Table

The Table provides a quick evaluation of frequency when used with oscilloscopes having a time-calibrated X axis. Entries in the 'Time' column apply to the length of one cycle in the observed waveform. Corresponding time and frequency units are: milliseconds - Hz; microseconds - kHz; nanoseconds - MHz.

Time	Frequency	Time	Frequency	Time	Frequency	Time	Frequency	Time	Frequency	Time	Frequency
1.0	1,000	5.5	182	10	100	55	18.2	100	10.0	550	1.82
1.25	800	5.75	174	12.5	80.0	57.5	17.4	125	8.00	575	1.74
1.5	667	6.0	167	15	66.7	60	16.7	150	6.67	600	1.67
1.75	571	6.25	160	17.5	57.1	62.5	16.0	175	5.71	625	1.60
2.0	500	6.5	154	20	50.0	65	15.4	200	5.00	650	1.54
2.25	444	6.75	148	22.5	44.4	67.5	14.8	225	4.44	675	1.48
2.5	400	7.0	143	25	40.0	70	14.3	250	4.00	700	1.43
2.75	364	7.25	138	27.5	36.4	72.5	13.8	275	3.64	725	1.38
3.0	333	7.5	133	30	33.3	75	13.3	300	3.33	750	1.33
3.25	308	7.75	129	32.5	30.8	77.5	12.9	325	3.08	775	1.29
3.5	286	8.0	125	35	28.6	80	12.5	350	2.86	800	1.25
3.75	267	8.25	121	37.5	26.7	82.5	12.1	375	2.67	825	1.21
4.0	250	8.5	118	40	25.0	85	11.8	400	2.50	850	1.18
4.25	235	8.75	114	42.5	23.5	87.5	11.4	425	2.35	875	1.14
4.5	222	9.0	111	45	22.2	90	11.1	450	2.22	900	1.11
4.75	211	9.25	108	47.5	21.1	92.5	10.8	475	2.11	925	1.08
5.0	200	9.5	105	50	20.0	95	10.5	500	2.00	950	1.05
5.25	190	9.75	103	52.5	19.0	97.5	10.3	525	1.90	975	1.03

# HENRY'S RADIO LIMITED

## ENGLAND'S LEADING ELECTRONIC CENTRES



HI-FI · COMPONENTS · TEST · PA · DISCOTHEQUE · ELECTRONIC ORGANS · MAIL ORDER

**MORE OF EVERYTHING AT LOW PRICES ALWAYS FROM HENRY'S**

\*Components from stock for almost all published designs.

**COMPLETELY NEW 10th EDITION CATALOGUE**



**350** pages fully detailed and illustrated covering every aspect of Electronics — plus data and information

**PRICE 55p** POST PAID (40p FOR CALLERS)

**10,000** Stock lines at Special Low Prices and Fully Guaranteed

**PLUS! FIVE 10p VOUCHERS FOR USE WITH PURCHASES**

**FREE** to Industry, Educational or any Organisation, including Schools and Colleges etc. Apply on Official heading to our "303" address

**A NEW HENRY'S CATALOGUE IS A MUST FOR ELECTRONICS TODAY!**

To: Henry's Radio Ltd. (Dept. RC),  
3, Albermarle Way, London, E.C.1.

Please send \_\_\_\_\_ copies at 55p each Post Paid

I enclose Cheque/PO for \_\_\_\_\_

(Use BLOCK CAPITALS—cut out and send with Cheque or Postal Order (No cash please). Use only for ordering catalogue).

Name \_\_\_\_\_

Address \_\_\_\_\_

RC

Allow 7-10 days from date of posting.

### TRANSISTOR AMPLIFIERS

NEW RANGES NOW IN STOCK (Leaflets Ref. Nos. 6 & 8) Post etc. 20p

4-300 4 TR	9 Volt 300 mW.	£1.75
104 4 TR	9 Volt 1 Watt	£2.12
304 4 TR	9 Volt 1 Watt	£2.47
555 6 TR	12 Volt 3 Watt	£2.75
PA7 6 TR	16 Volt 7 Watt	£3.62
608 6 TR	24 Volt 10 Watt	£4.12
410 4 TR	28 Volt 10 Watt	£4.97
MPA12/3 6 TR	18 Volt 12 Watt	£4.50
MPA12/15 6 TR	35 Volt 12 Watt	£5.25
Z30 9 TR	30 Volt 20 Watt	£3.75
PA25 10 TR (Special)	25 Watt	£7.50
Z50 30 Volt	40 Watt	£5.47
PA50 12 TR (Special)	50 Watt	£9.50
100 100W.	with Power Supply	£45.00 post 45p

**OPTIONAL POWER SUPPLIES** Post, etc. 20p  
P.500 (One or Two) for 104, 304 £2.62  
PS.20 (One or Two) for PA7 £3.47  
MU24/40 (One or Two) for

MPA12/3 or MPA12/15 £4.50  
or PZ6 for Z30 £6.97  
PZ8 for Z50 £5.97  
Transformer £2.25  
P11 for 608 £2.87  
P15 for 410 £2.62  
MU442 for one or two PA25, or one only for PA50 £6.50

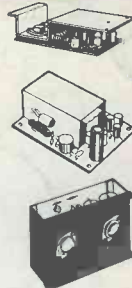

### HI-FI TO SUIT



**EVERY POCKET**

**CHOOSE FROM 100 STEREO SYSTEMS**

and a complete range of individual units in stock — Demonstrations all day — visit our new Hi-Fi Store. **LOW CASH or CREDIT/HP TERMS** (Credit terms from £30 purchase — callers only). **FREE** — Stock list No. 16/17 on request. **BEST VALUE IN U.K.**

### GARRARD TAPE DECK



Price £9.97

p&p 33p

9 volt operated 2-speed tape deck fitted Record/Replay  $\frac{1}{2}$  track and Erase/Bias Osc. Head. Complete with Oscillator/Record head circuit Unit size 9" x 6 $\frac{1}{2}$ " x 1 $\frac{1}{2}$ " and 2 $\frac{1}{2}$ " below motor board. Takes up to 4" spools. Supplied brand new. 300ft. 3 $\frac{1}{2}$ " Tape & Spool 40p

### NEW MINIATURE LOW-COST AMPLIFIER

MODEL 4-300

9 volt operated or mains unit optional transformer (MT98 70p 1-10mV adjustable sensitivity. P/P output for 3-8 ohms. Fitted volume control and leads. Size 5 $\frac{1}{2}$ " x 1 $\frac{1}{2}$ " x  $\frac{3}{4}$ ". Thousands of uses takes magnetic, dynamic and crystal inputs direct. Output 300 mW — very high gain — built-in rectifier circuit. Complete with FREE leaflet No. 8.

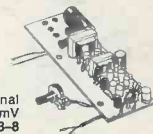

Price **£1.75** p&p 15p

### HENELEC EQUIPMENT (as previously advertised)



#### SELF-POWERED SILICON PRE-AMPLIFIERS

FET.154 Stereo £16.50 Post 25p  
FET.9/4 Mono with mike mixer £12.50 Post 20p

#### SILICON POWER AMPLIFIERS FOR USE WITH ABOVE

PA25 25 watts into 8 ohms £7.50 Post 20p  
PA 50 50 watts into 4 ohms £9.50 Post 20p  
MU442 Power Supply for 1 or 2 PA25's or 1 only PA50 £6.00 Post 20p

#### PACKAGE DEALS

FET.9/4 plus PA25 plus MU442 £25 Post 40p  
FET.9/4 plus PA50 plus MU442 £27 Post 40p  
FET.154 plus 2xPA25 plus MU442 £36 Post 50p  
FET.154 plus 2xPA50 plus MU442 £40 Post 50p

**NO SOLDERING—JUST EDGE CONNECTORS AND DIN PLUGS/SOCKETS**

**FREE BROCHURE No. 25**

### BUILD YOURSELF A QUALITY RADIO

Excellent printed circuit design with full power output. Fully tuneable on both MW/LW bands. 7 Mullard transistors. Fitted 5in. speaker. Room-filling power. Easy to build with terrific results. Two-colour leathercloth cabinet with silvered front. All local and continental stations. Complete detailed instructions. Ask for Leaflet No. 1. Total cost £6.98 p.p. 35p All parts sold separately.



### SINCLAIR PROJECT 60 PACKAGE DEALS

2xZ30 amplifier, stereo 60 pre-amp. PZ5 power supply. £16.75 Carr. 40p. Or with PZ6 power supply £18.25, Carr. 40p. 2xZ50 amplifier, stereo 60 pre-amp, PZ6 power supply £20.25, Carr. 40p. Transformer for PZ8 £2.25 extra. Any of the above with Active Filter unit add £4.75 or with pair Q16 speakers add £15.00 Also **NEW FM TUNER** Price £21.00

### BUILD THIS VHF FM TUNER

5 MULLARD TRANSISTORS 300 kc/s BANDWIDTH. PRINTED CIRCUIT. HIGH FIDELITY REPRODUCTION. MONO AND STEREO. A popular VHF FM Tuner for quality and reception of mono and stereo. There is no doubt about it — VHF FM gives the REAL sound. All parts sold separately. Free leaflet Nos. 3 & 7. TOTAL £6.97 p.p. 20p Cabinet £1.00. Decoder Kit £5.97. Tuning Meter £1.75. Mains unit (optional) Model PS900 £2.47 Mains unit for Tuner and Decoder PS1200 £2.62



Electronic Components, Audio and Test Gear Centre  
**356 EDGWARE ROAD, LONDON, W.2.**  
Tel: 01-402 4736

High Fidelity Sales & Demonstrations Centre  
**354 EDGWARE ROAD, LONDON, W.2.**  
Tel: 01-402 5854

Electronic Organs, P.A. & Discotheque Centre  
**309 EDGWARE ROAD, LONDON, W.2.**  
Tel: 01-723 6963

Mail Orders, Special Bargain Shop, Industrial Sales  
**303 EDGWARE ROAD, LONDON, W.2.**  
Tel: 01-723 1008/9

"354" & "356" OPEN SIX FULL DAYS A WEEK 9 am to 6 pm MONDAY TO SATURDAY